



# DRIVE IN X-CHANGE™

TRIPLE PLAY Patent Pending - Universal Push Tube

## ASSEMBLY / OWNER'S MANUAL

Part No: 15-0300

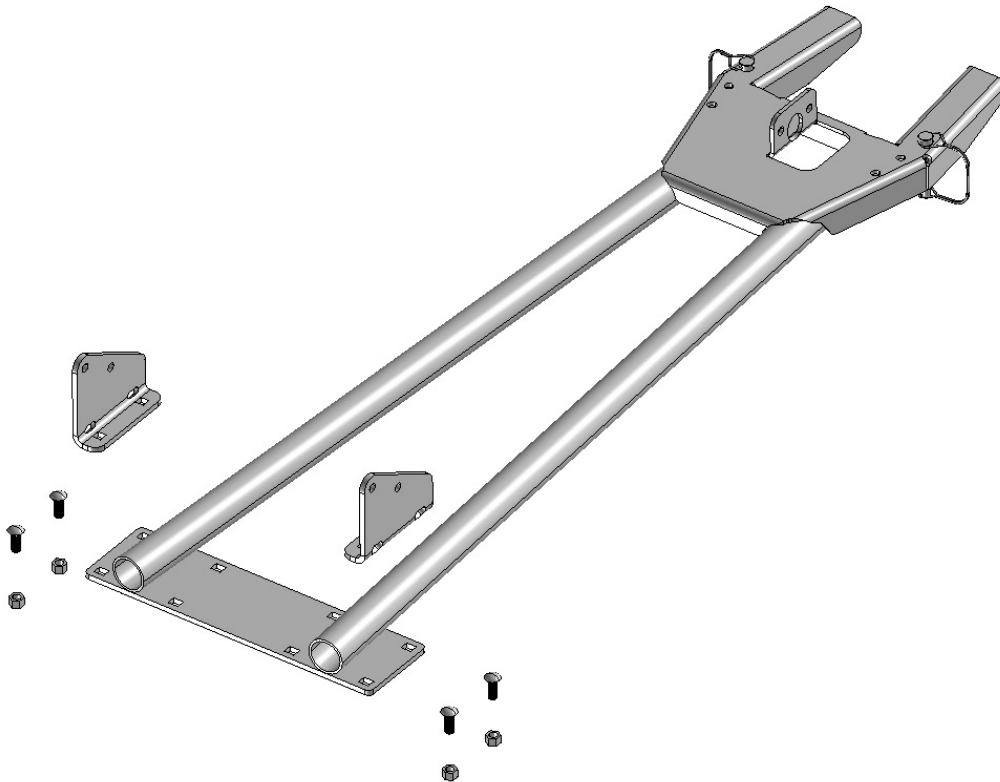

# OPERATING INSTRUCTIONS

Congratulations! You've just purchased the most durable accessory component in the industry. Cycle Country accessories work great summer or winter. With proper care and maintenance, your Cycle Country accessory will last for years to come!

## NOTICE

**The Drive In X-Change™ system requires a Triple Play Blade Attachment and one or more of these components to fully function:**

- **Universal Push Tube**
- **Drive In X-Change™ Accessories**

Please read and understand all assembly instructions, notices and warnings before assembling and operating your accessory.

**Follow these guidelines to ensure satisfactory operation:**

- Periodically check for wear and tightness of all fasteners. Replace or re-torque fasteners as necessary.
- For best results, use with a winch system or a PowerMax Electric Lift. Attach lifting mechanism to the Push Tube only.
- Read this manual and your ATV operators manual before use.

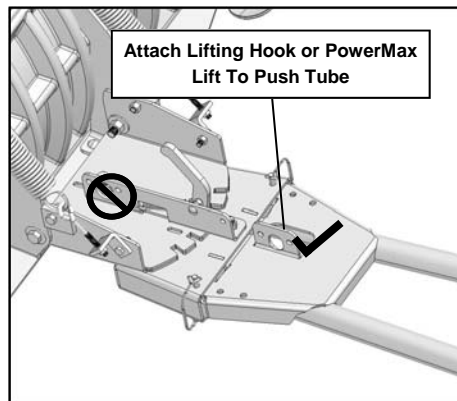

# SAFETY INFORMATION

Cycle Country accessories were designed with your safety in mind. In order to protect you and your vehicle, certain parts of the accessory and/or hardware may be designed to fail when the equipment is over-stressed.

## ⚠ WARNING

**To avoid personal injury or damage to your vehicle:**

Read and understand all cautions, warnings, notices, and instructions

Do not carry unsecured loads at any time

Do not exceed the load capacity of the winch or lift.  
Refer to the owner's manual.

Keep yourself, other people and pets away from moving parts during operation

Exercise caution during operation

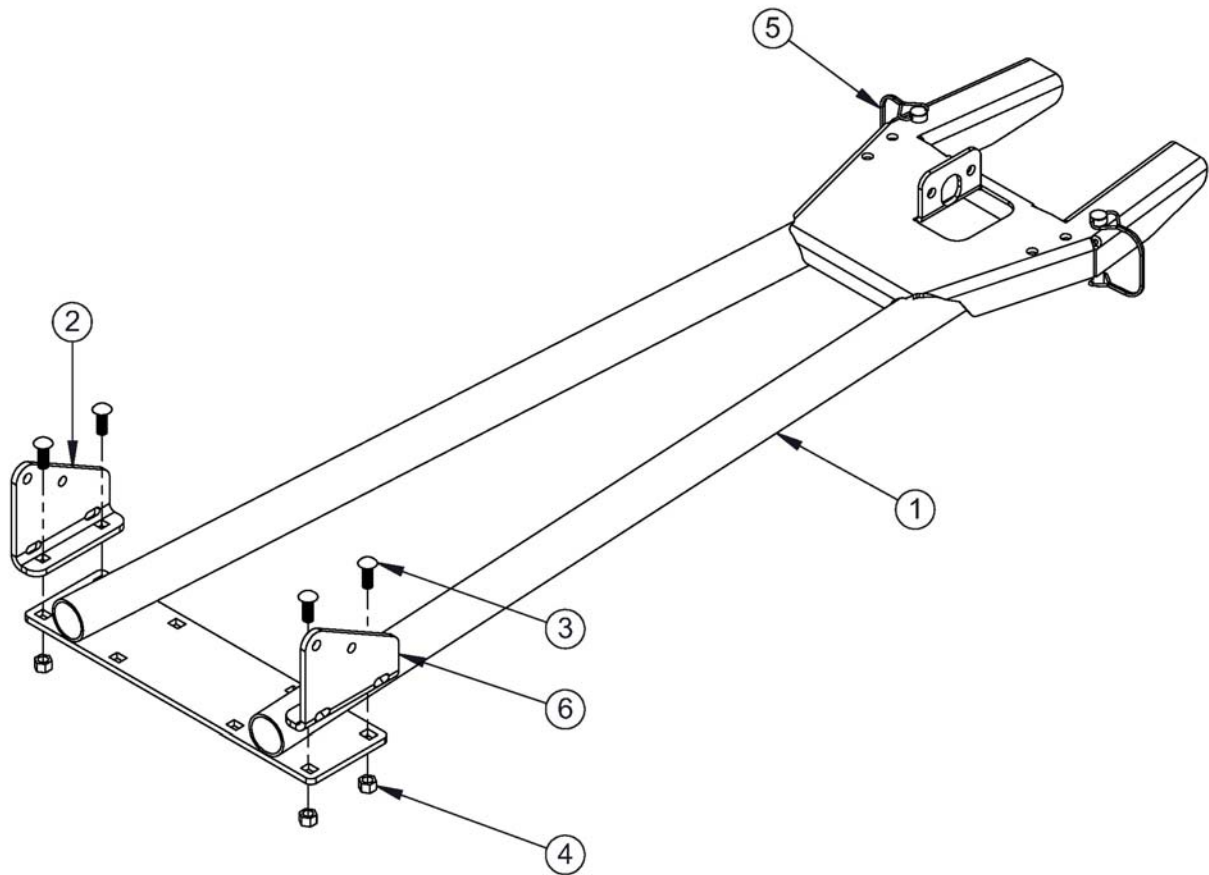

## Model Number 15-0300 Parts List

ITEM NO.	QTY.	PART NO.	DESCRIPTION
1	1	CYC6066	Pushtube Weldment
2	1	CYC6071	Attaching Bracket LH
3	4	PUR1185	Carriage Bolt 3/8" x 1"
4	4	PUR1272	Locknut 3/8" Nylock
5	2	PUR1286	3/8" x 2 1/2" Lock Pin
6	1	CYC6072	Attaching Bracket LH

**PARTS INFORMATION:**  
 Replacement fasteners are common-type and can be purchased locally. Use minimum Grade 5 zinc-coated fasteners.

## BEFORE YOU BEGIN:

- Please read and understand all instructions.
- Verify all parts and tools are accounted for.
- To ensure a satisfactory installation, follow all steps correctly and in the sequence described.
- All directions referring to right and left are when the rider is sitting on the machine

## TOOLS REQUIRED:

- Basic Hand Wrench and Socket Set
- Torque Wrench

## INSTALLATION NOTES:

### NOTICE

Attaching brackets, Items #2 and #6, have a slight amount of lateral adjustment to account for varying plow mount tolerances. Set the width of the attaching brackets according to mount width requirements before torquing fasteners

## PUSH TUBE ASSEMBLY - CYCLE COUNTRY CONFIGURATION:

1. To configure the Triple Play Push Tube for use with a Cycle Country plow mount, place the attaching brackets, Items #2 and #6, onto the push tube weldment, Item #1 as shown in Illustration 1.
2. Fasten the attaching brackets with carriage bolts, Item #3 and lock nuts, Item #4. See Illustration 1.

### NOTICE

Installer may choose to pre-install the completed push tube on the mount to set proper bracket width

3. Torque fasteners to specification.



**FASTENER TORQUE:**  
Item #4 - 30ft. lbs. (40.6 Nm)

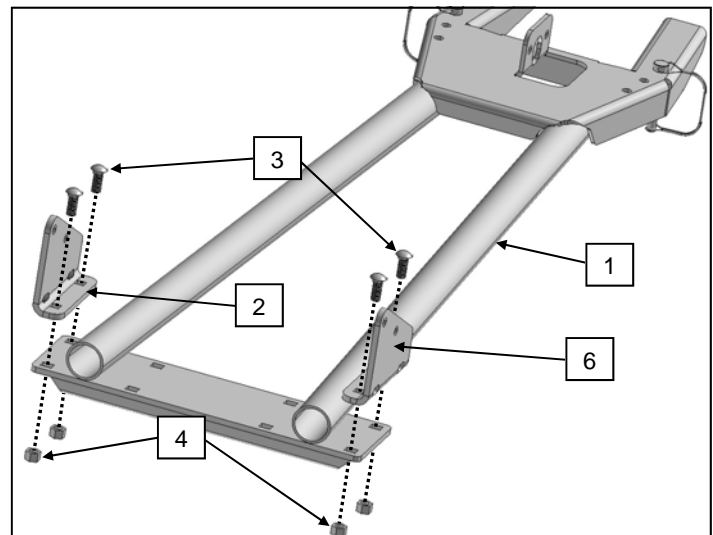

Cycle Country Configuration

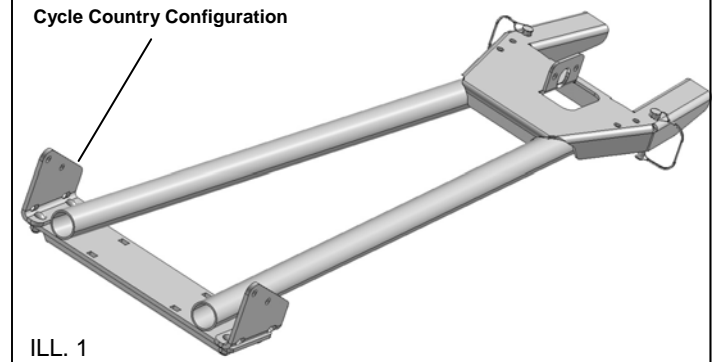

ILL. 1

## PUSH TUBE ASSEMBLY - MOOSE CONFIGURATION:

1. To configure the Triple Play Push Tube for use with a Moose plow mount, place the attaching brackets, Items #2 and #6, onto the push tube weldment, Item #1 as shown in Illustration 2.
2. Fasten the attaching brackets with carriage bolts, Item #3 and lock nuts, Item #4. See Illustration 2.

### NOTICE

Installer may choose to attach the completed push tube to the mount to set proper bracket placement

3. Torque fasteners to specification.



**FASTENER TORQUE:**  
Item #4 - 30ft. lbs. (40.6 Nm)

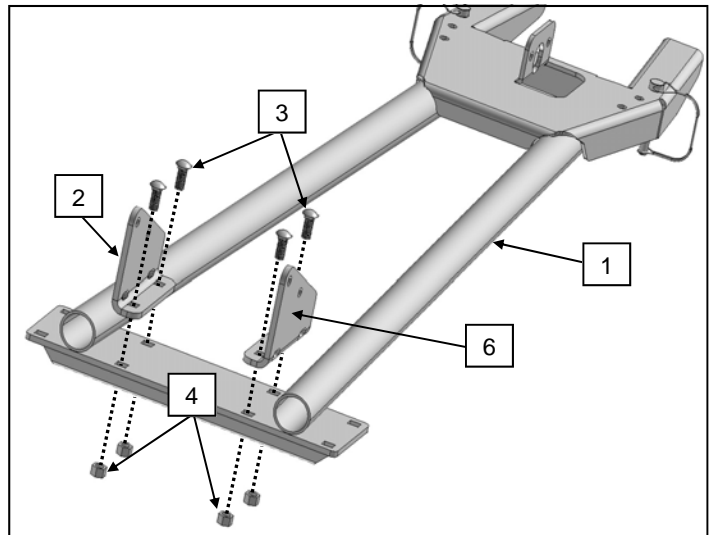

Moose Configuration

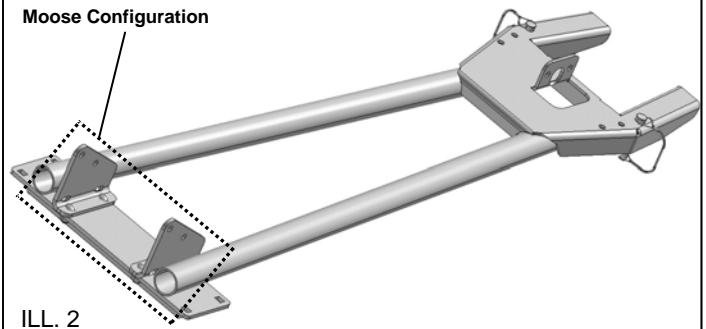

ILL. 2

## PUSH TUBE ASSEMBLY - WARN CONFIGURATION:

1. To configure the Triple Play Push Tube for use with a Warn plow mount, place the attaching brackets, Items #2 and #6, onto the push tube weldment, Item #1 as shown in Illustration 3.
2. Fasten the attaching brackets with carriage bolts, Item #3 and lock nuts, Item #4. See Illustration 3.

### NOTICE

Installer may choose to attach the completed push tube to the mount to set proper bracket placement

3. Torque fasteners to specification.



**FASTENER TORQUE:**  
Item #4 - 30ft. lbs. (40.6 Nm)

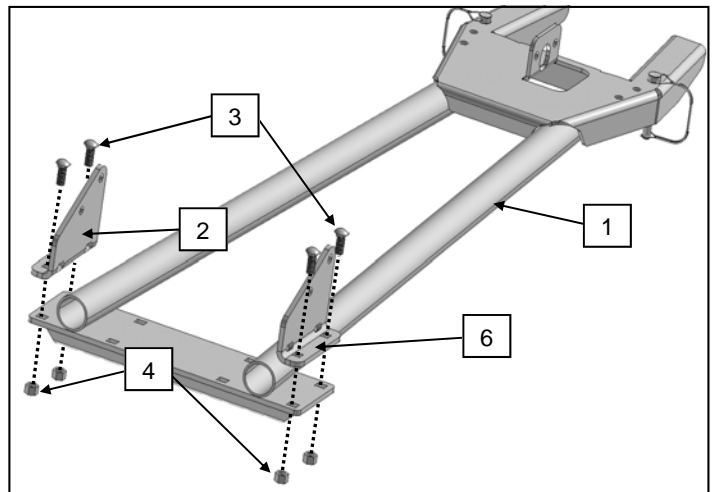

Warn Configuration

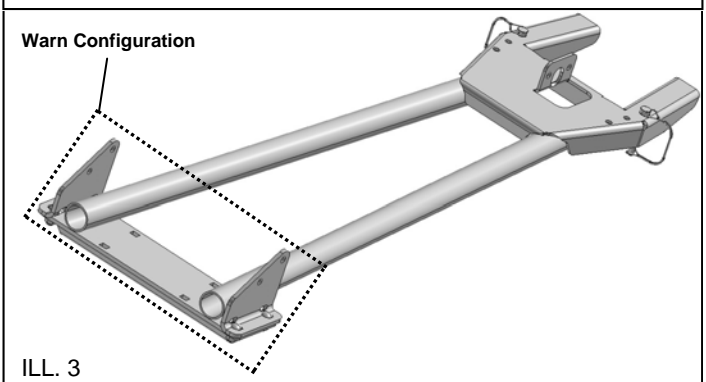

ILL. 3

## PUSH TUBE ENGAGEMENT:

1. Drive machine forward while directing the push tube forks into the attachment. **NOTE:** *It may be necessary to lift the push tube slightly during engagement.*
2. Lift the attachment off the ground and verify the lock pin holes are aligned.
3. Insert lock pins. See Illustration 4.  
**NOTE:** *Recommended lock pin installation is from the bottom side for easier removal and reduces the chance of catching on obstacles.*

### NOTICE

**Stop engine and lock parking brake  
before dismounting the ATV to install lock pins**

4. Attach winch hook or PowerMax Electric Lift to the push tube. See Illustration 4.
5. To disengage from the attachment, raise the push tube and remove the lock pins. Lower the push tube to the ground and back the machine away, pulling the push tube forks out of the attachment.

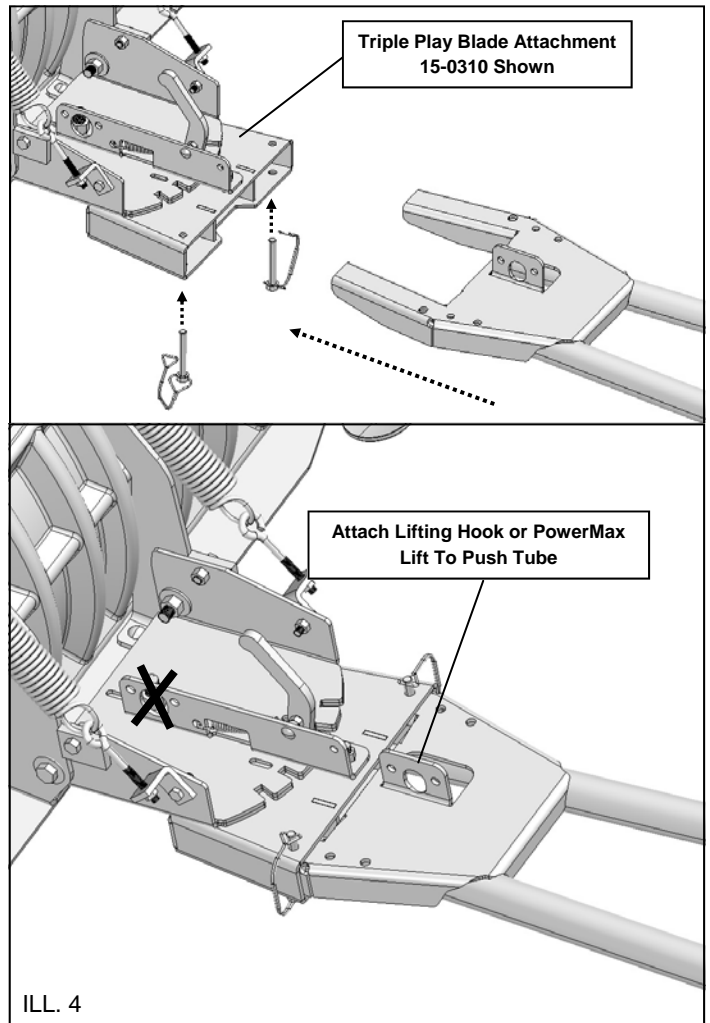

ILL. 4



## One Year Limited Warranty

For the period of one (1) year from the purchase date, Cycle Country Accessories Corporation will replace for the original purchaser, free of charge, any part or parts found upon examination by Cycle Country Accessories Corporation to be defective in material, workmanship, or both.

All transportation costs incurred submitting product to Cycle Country for warranty consideration must be borne by the purchaser. If Cycle Country determines that the product must be returned to the factory for credit, please call 1-800-841-2222 for a Return Merchandise Authorization (RMA) number and shipping instructions.

This warranty does not apply to parts that have been damaged by accident, alteration, abuse, improper maintenance, normal wear, or other causes beyond the manufacturer's control. In order to protect you and your ATV, certain parts of the plow system and/or hardware are designed to fail when the equipment is over-stressed.

Peripheral products such as engines, electric motors, and actuators may carry an original manufacturer's warranty. Please call Cycle Country Accessories Corporation for more information.

**CYCLE COUNTRY ACCESSORIES CORPORATION**

**1701 38TH AVE W**

**SPENCER, IA 51301**

**SERVICE: 800-841-2222 FAX: 712-262-0248**

**E-MAIL: [ccac@cyclecountry.com](mailto:ccac@cyclecountry.com)**

**WEB: [www.cyclecountry.com](http://www.cyclecountry.com)**