



UTV STORM CHASER PLOW PUSH TUBE KIT

P/N 34-0070

OWNER'S MANUAL

Application

MID-BODY UTV MOUNT NO. 34-XXXX, ALL MOUNT NO. 34-0050

**ATTENTION DEALER: CUSTOMER MUST RECEIVE A COPY OF THIS MANUAL
AT THE TIME OF SALE.**

Before you begin, please read these instructions and check to be sure all parts and tools are accounted for. These instructions will help you to become familiar with operation of the plow push frame. Instructions contain details required to install, service the contents of this kit, for adjustment and maintenance.

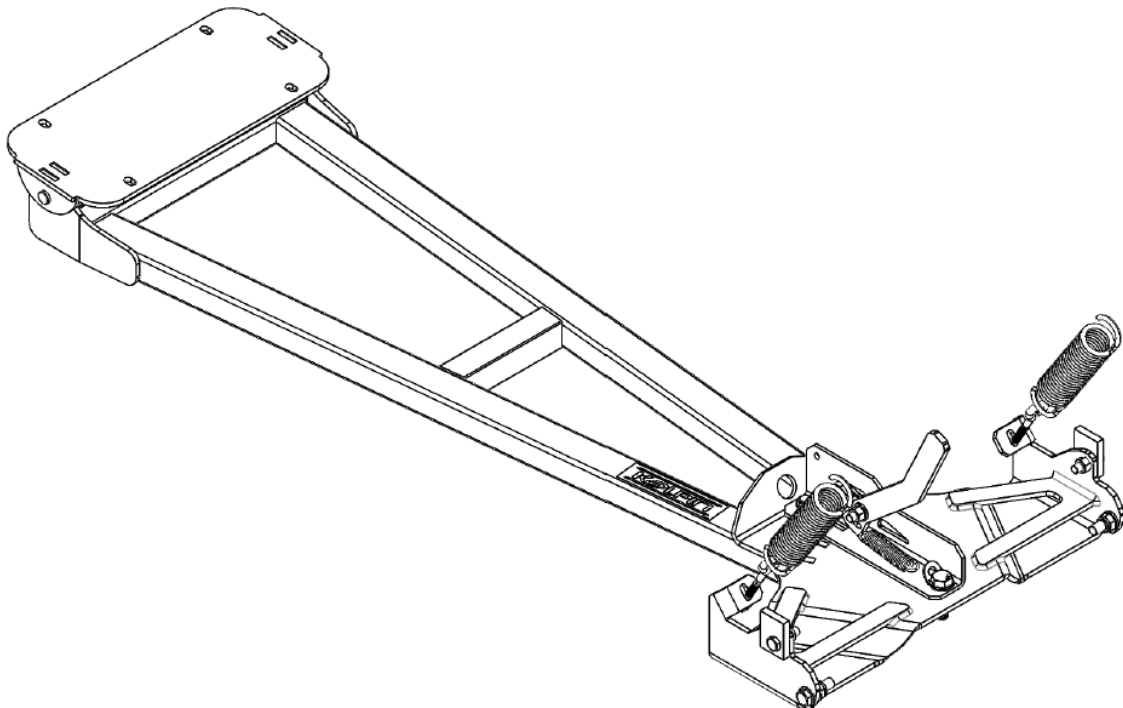

INTRODUCTION

Congratulations! You've just purchased one of the industry's top plow system component. The Kolpin Plow Push Frame works great for all types of plowing. With proper care and maintenance, your plow push frame will last for many years!

The blade pivot design allows the operator to select multiple angled left-or-right positions, and also incorporates a spring-loaded 'trip' system that allows the blade to handle impacts with small obstructions. Additionally, this plow frame will handle light to medium-duty summer landscape work.

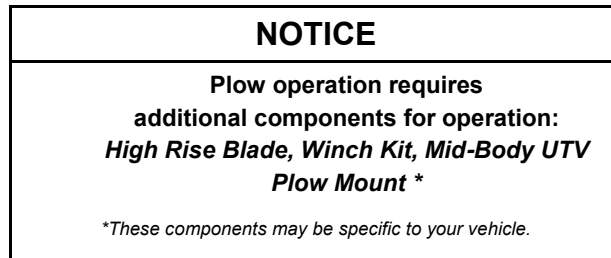

Please read and understand all adjustment/maintenance instructions, notices and warnings before assembling and operating your plow system.

Follow these guidelines to ensure satisfactory operation:

- Read this manual and your UTV operators manual before use.
- Periodically check for wear and tightness of all fasteners. Replace or re-torque fasteners as necessary.
- Before first use, set plow in the furthest right or left angled position to check for clearance between the plow and front tires.
- Operate with extreme caution on slopes and rough terrain. Be familiar with the area before you plow.
- Be aware of immovable objects that could be hidden in the area you are plowing.
- To avoid damage when pushing snow into a pile, reverse direction before raising the plow blade.
- Do not ram the plow blade into piles of snow. ****Slow down before hitting a pile.****
- For best results, set the suspension preload of your UTV to the stiffest setting.
- To reduce steering effort and increase mobility, set the air pressure of your tires to the maximum pressure specification.
- The plow skids are adjustable. General skid setting is even with the plow wear bar bottom edge, higher settings reduce the chance of rocks and gravel from being collected.
- To increase traction during plow operation, operators can try: Securing weight to the UTV for additional tire downforce, reducing tire air pressure, or installing tire chains.
- The plow blade assembly is designed to 'trip' when it strikes an object or digs in too far. When pressure is released, the plow springs back into position. *Spring tension can be increased by tightening the locknuts on the bottom of the eyebolts. For less spring tension, loosen the locknuts.*
- Always wear appropriate protective clothing as recommended in UTV's operator's manual.
- Keep away from blade and moving parts during operation.
- Keep these instructions for future reference.
- All directions referring to right and left are when the rider is sitting on the machine.
- Your Kolpin accessory is exclusively designed for your vehicle.

SAFETY INFORMATION

Our plow systems were designed with your safety in mind. Please read and understand all Cautions, Notices and Warnings in this manual before you begin. In order to protect you and your UTV, certain parts of the plow system and/or hardware are designed to fail when the equipment is over-stressed.



DANGER



TO AVOID SERIOUS INJURY OR DEATH:

1. DO NOT EXCEED 5 MPH (8 KM/H) WITH THE BLADE INSTALLED.
2. OPERATE WITH EXTREME CAUTION ON SLOPES, STEEP GRADES, AND ROUGH TERRAIN.
3. ALLOW NO RIDERS ON BLADE OR ATV WHILE MOVING OR STATIONARY.
4. KEEP BYSTANDERS AWAY FROM THE BLADE OR ATV / UTV WHILE MOVING OR STATIONARY.
5. WHEN PUSHING HEAVY MATERIAL, DIRECTION CONTROL MAY BECOME DIFFICULT.
6. BEFORE ADJUSTING BLADE: STOP ATV ENGINE; SET AND LOCK BRAKES; RAISE AND LOCK BLADE IN UP POSITION. DO NOT ATTEMPT TO RAISE BLADE BY HAND; USE THE LIFT MECHANISM ONLY.
7. LOWER BLADE TO DOWN POSITION WHEN BLADE AND ATV / UTV ARE NOT IN USE.
8. READ PUSH FRAME'S INSTRUCTION SHEETS AND ATV OWNER MANUAL.

BEFORE YOU BEGIN:

- Your Kolpin accessory is exclusively designed for your vehicle.
- Please read and understand all instructions.
- Verify all parts and tools are accounted for.
- To ensure a satisfactory installation, follow all steps correctly and in the sequence described.
- Keep these instructions for future reference or for informational requests.
- To facilitate installation, make sure that your vehicle is clean and free of debris.
- All directions referring to right and left are when the rider is sitting on the machine

TOOLS REQUIRED:

- 13mm wrench or 13mm socket
- 15mm wrench or 15mm socket
- 17mm wrench and 17mm socket
- 19mm wrench and 19mm socket
- 21mm wrench or 21mm socket
- 22mm wrench or 22mm socket
- Long nose pliers or spring puller or shoe-string sized rope

APPROXIMATE ASSEMBLY TIME: 15 minutes

Note: The Kolpin Plow Push Frame kit comes mostly assembled from factory. Some assembly is required.

RE-TORQUE ALL BOLTS AND NUTS AFTER THE FIRST 30 MINUTES OF USE.

Kit Contents:

Item	Qty	Part Description	Part Number
1	1	Push Frame Welded Assembly	-
2	1	Blade Hinge Pivot Frame	-
3	1	Pivot Lock Lever	33-0070-CP04-B
4	1	Pivot Lock Lever Bracket	33-0070-CP03
5	2	Blade Trip Spring	PUR1409
6	2	Eye Bolt, Zinc Plated, Full Thread, M8-1.25 x 110mm	PUR1216
7	2	Blade Stopper Plate	CYC0813
8	1	Lever Tension Spring	PUR1437
9	2	Hex Nylon Lock Nut, Zinc Plated, M8-1.25	-
10	2	Hex Nylon Lock Nut, Zinc Plated, M12-1.75	-
11	4	Hex Nylon Lock Nut, Zinc Plated, M10-1.5	-
12	1	Hex Nylon Lock Nut, Zinc Plated, M14-2.0	-
13	1	Hex Bolt, Zinc Plated, M10-1.5 x 50mm	-
14	1	Large bushing, Ø11mm ID x Ø25 mm OD x 14mm LG	-
15	4	Flat washer, Zinc Plated, M10	-
16	1	Small bushing, Ø11mm ID x Ø25 mm OD x 8mm LG	-
17	3	Hex Bolt, Zinc Plated, M10-1.5 x 35mm	-
18	2	Hex Bolt, Zinc Plated, M12-1.75 x 40mm	-
19	4	Flat washer, Zinc Plated, M12	-
20	1	Spring Loop Washer Plate	-
21	1	Hex Bolt, Zinc Plated, M14-2.0 x 50mm	-
22	1	Kolpin UTV Mount Plate	34-0070CP07
23	2	Clevis Pin	-
24	2	Hairpin Cotter Pin	-
25	1	Kolpin Decal	-
26	1	Owner's Manual (not shown)	-

Kit Contents (continued):

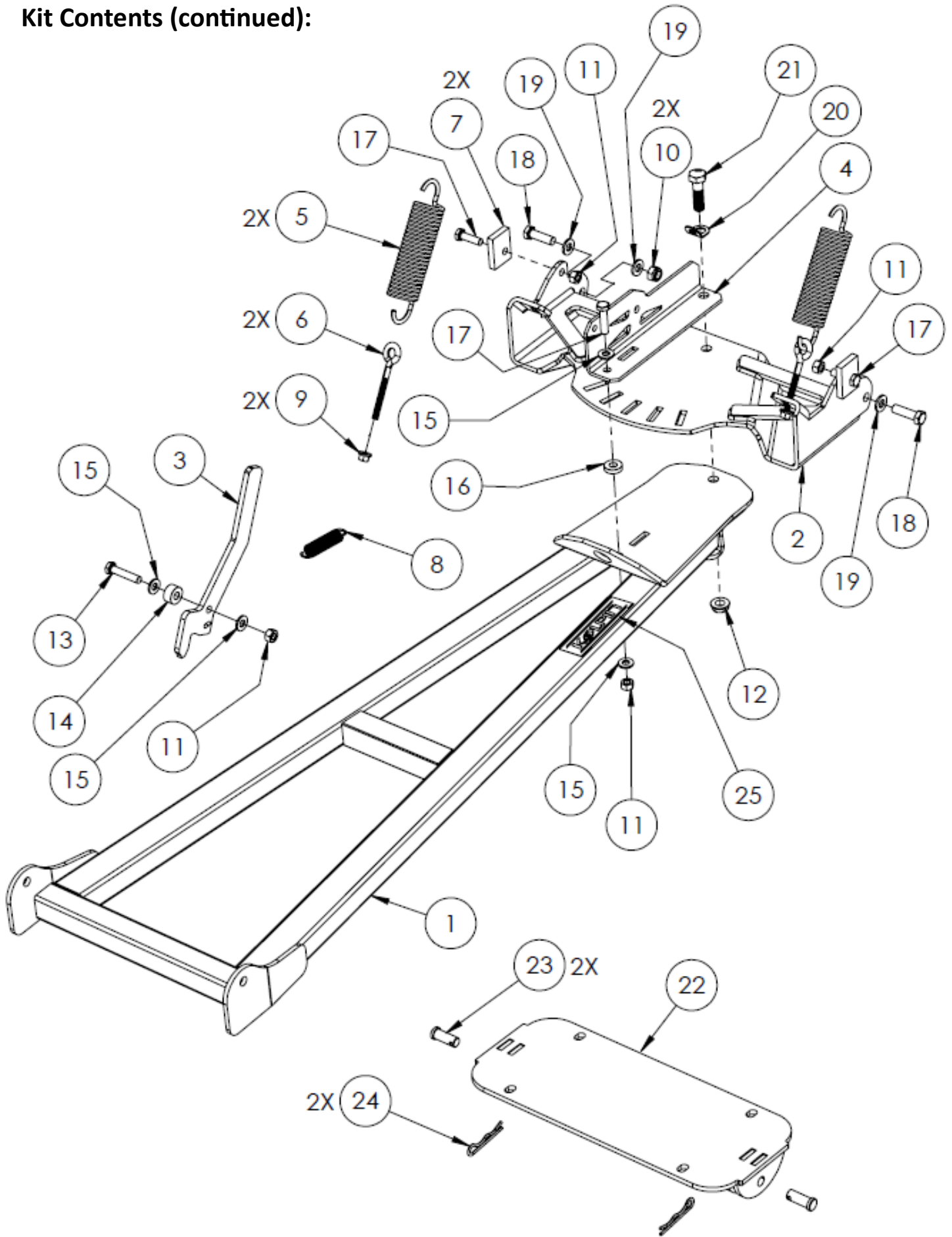

ASSEMBLY INSTRUCTIONS:

PIVOT LOCK LEVER INSTALLATION:

1. Position the pivot lever, item #3, into the pivot lock bracket, item #4. Insert the M10 bolt, item #13, and M10 washer, item #15, thru the bracket as shown. Then slide bushing, item #14, onto bolt threads and follow with lever. Fasten with M10 washer and M10 lock nut, item #4. Tighten nut, then back out 1/8 - 1/4 turn to allow lever to pivot freely. The pivot lever assembly is ready to be mounted on push frame. (See illustration 1-1). *Note, the lever must pivot freely.*
2. Position blade hinge pivot frame, item #2, and pivot lever assembly onto push frame, item #1, as shown. Insert M14 bolt, item #21, and spring loop washer plate, item #20, thru pivot lever assembly - blade hinge frame - push frame. Fasten with M14 nut, item #12. Tighten M14 nut, then back out 1/8 - 1/4 turn to allow blade hinge frame to pivot freely. (See illustration 1-2). *Note, blade hinge must pivot freely.*
3. Insert M10 bolt, item #17, and M10 washer, item #15, thru pivot lever assembly - small bushing, item #16, - push frame. Fasten with M10 washer, item #15, and M10 nut, item #11. Tighten to specification. (See illustration 1-2). *Note, the small bushing fits in between pivot bracket and push frame.*

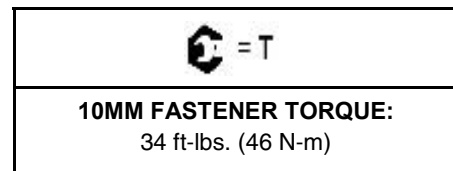
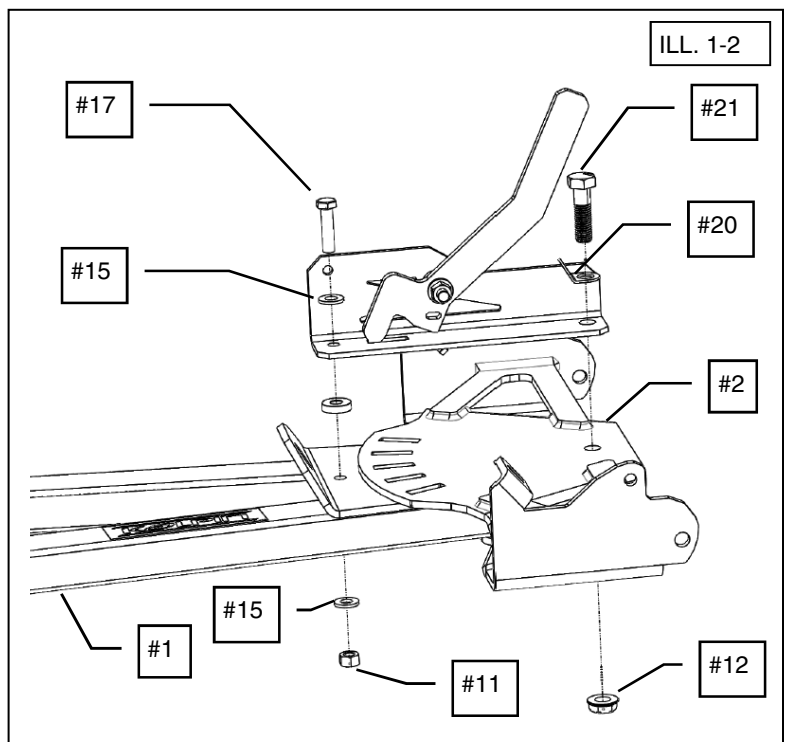
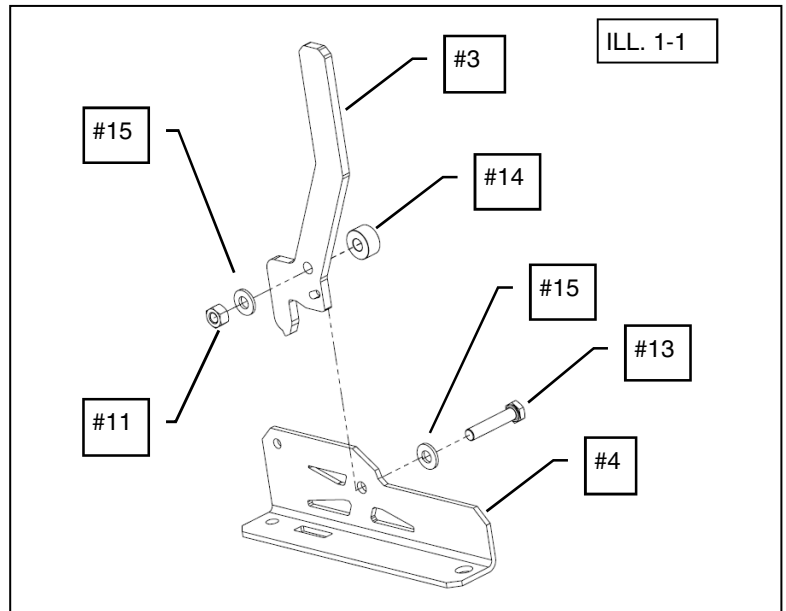

ASSEMBLY INSTRUCTIONS (continued):

PIVOT LOCK LEVER INSTALLATION (continued):

3. Install lever spring, item #8, to lever and loop washer holes as shown. Using a rope or a spring puller allows for easy installation of spring. (See illustration 1-3).

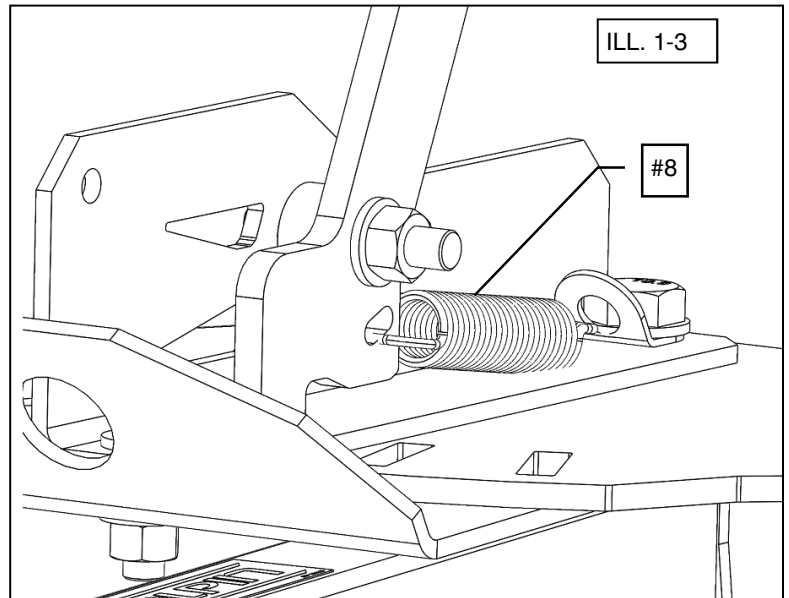

PUSH FRAME INSTALLATION ONTO BLADE ASSEMBLY:

1. Attach the assembled push frame to the blade. Insert M12 hex bolts, item #18, thru the M12 washers, item #19, and thru holes in the blade and push frame. Fasten the push frame to the blade using M12 hex nuts, item #10, and M12 washers, item #19. Tighten nut, then back out 1/8 - 1/4 turn to allow blade to hinge freely. (See illustration 2-1). *Note, bolt should be tight enough to not move, but the blade must rotate freely.*
2. Assemble blade trip springs, item #5, and eyebolts, item #6, between the blade assembly and the pivot spring tab brackets. Fasten eyebolts to frame tab with M8 hex nylon nuts, item #9, onto the eyebolts until 2-3 threads show thru the locking feature. (See illustration 2-2).

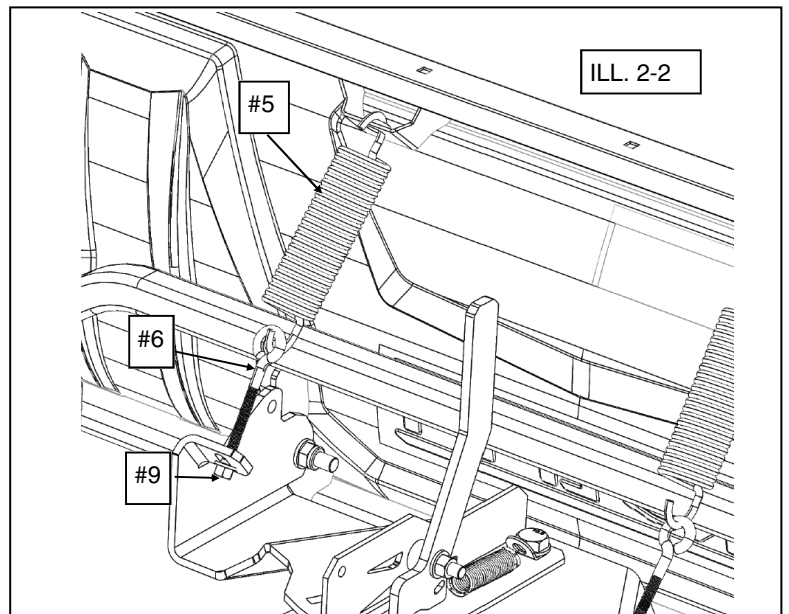
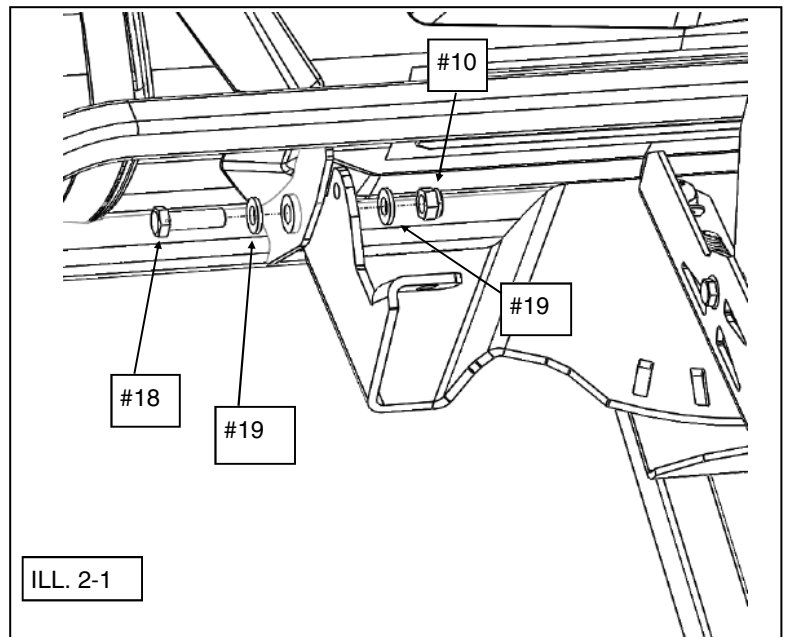

ASSEMBLY INSTRUCTIONS

(continued):

PUSH FRAME INSTALLATION ONTO BLADE ASSEMBLY

(continued):

3. Install the blade stopper plates, item #7, onto blade hinge pivot frame. Fasten with M10 hex bolt, item #17, and M10 hex nuts, item #11, as shown. (See illustration 2-3). *Note, do not tighten fasteners at this time.*
4. Once plow system is mounted to the ATV, adjust the blade stops and blade trip spring tension as desired to achieve best performance. (See illustration 2-4).
5. Tighten the blade stopper plate fasteners to specification.

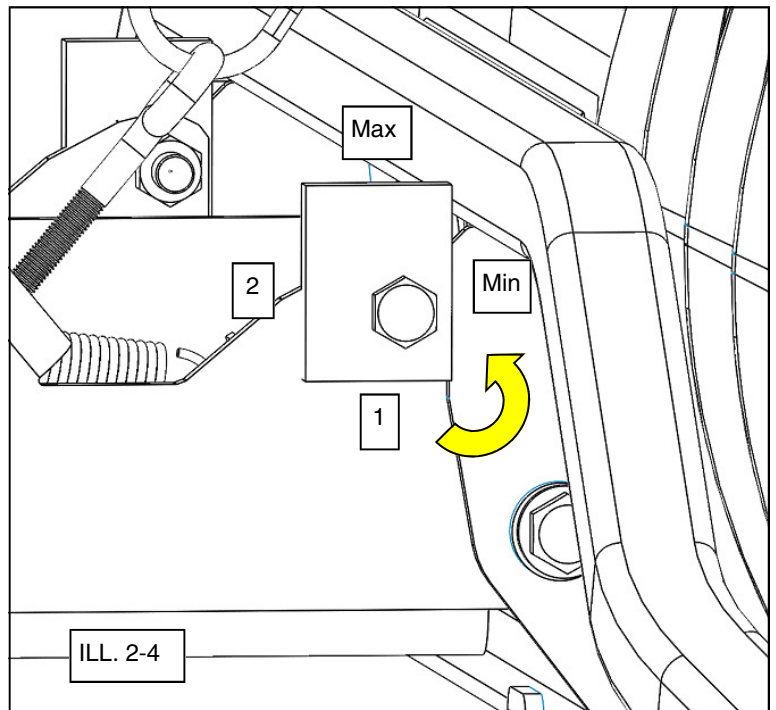
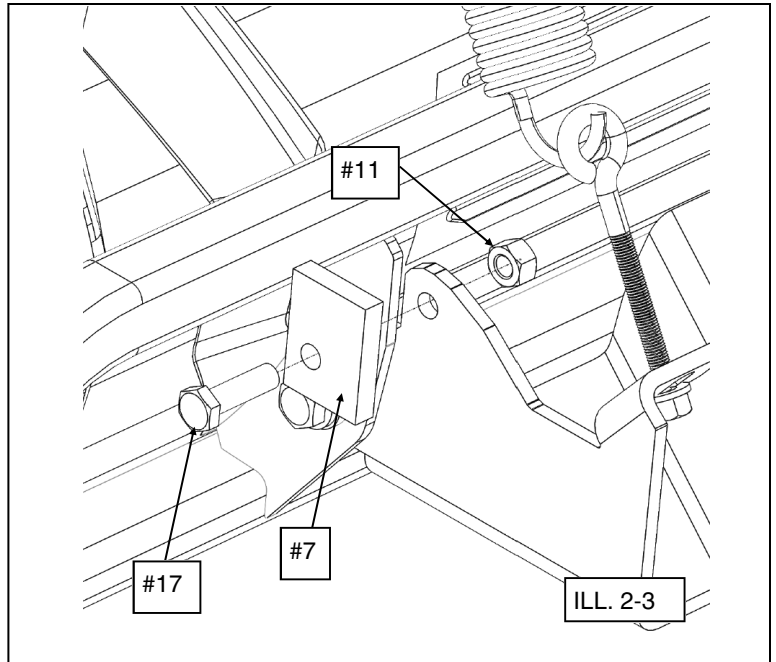

BLADE STOPPER ADJUSTMENT

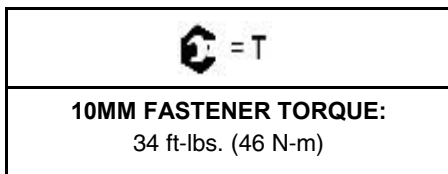

ASSEMBLY INSTRUCTIONS (continued):

UTV MOUNT PLATE INSTALLATION ONTO VEHICLE:

1. Install the UTV mount plate, item #22 onto the vehicle specific plow mid-mount (not included in kit). Fasten using the hardware provided in the vehicle specific plow mid-mount kit, as shown. (See illustration 3-1).
2. Once mount plate is installed on the UTV, the push frame assembly attaches to plate with the clevis pins, item #23, and hairpin cotter pins, item #24, as shown. (See illustration 3-2).

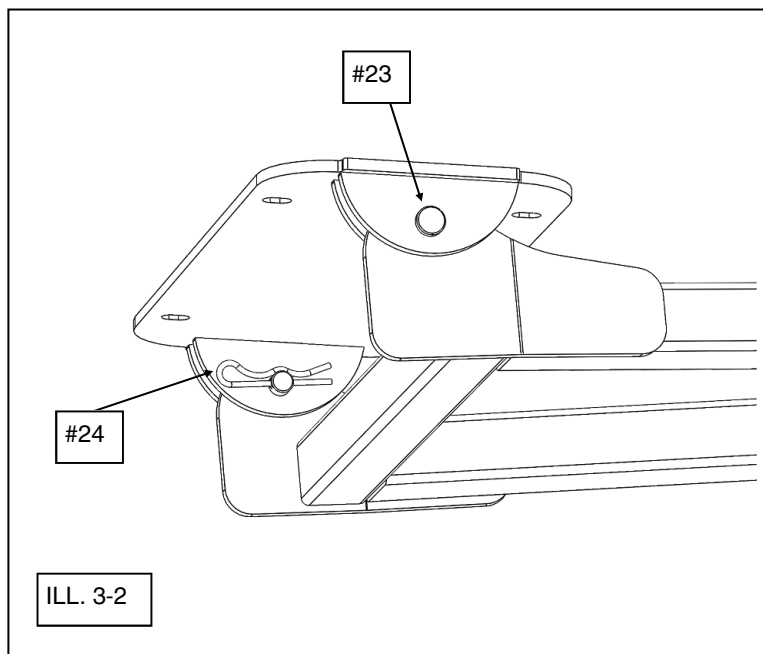
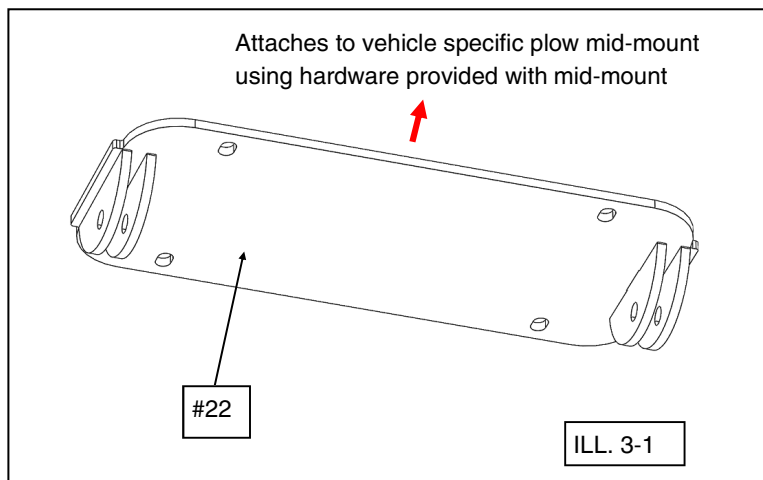

SPARE KITS		Hardware kit P/N 34-0070- HDW	Pivot Lock Lever kit P/N 33-0070-CP04-B	Pivot Lock lever Bracket kit P/N 33-0070-CP03	Clevis Pin kit P/N PUR3308
Item	Description				
3	Pivot Lock Lever		1x		
4	Pivot Lock Lever Bracket			1x	
5	Blade Trip Spring	2x			
6	Eye Bolt, Zinc Plated, Full Thread, M8-1.25 x 110mm	2x			
7	Blade Stopper Plate	2x			
8	Lever Tension Spring	1x			
9	Hex Nylon Lock Nut, Zinc Plated, M8-1.25	2x			
10	Hex Nylon Lock Nut, Zinc Plated, M12-1.75	2x			
11	Hex Nylon Lock Nut, Zinc Plated, M10-1.5	4x			
12	Hex Nylon Lock Nut, Zinc Plated, M14-2.0	1x			
13	Hex Bolt, Zinc Plated, M10-1.5 x 50mm	1x			
14	Large bushing, Ø11mm ID x Ø25 mm OD x 14mm LG	1x			
15	Flat washer, Zinc Plated, M10	4x			
16	Small bushing, Ø11mm ID x Ø25 mm OD x 8mm LG	1x			
17	Hex Bolt, Zinc Plated, M10-1.5 x 35mm	3x			
18	Hex Bolt, Zinc Plated, M12-1.75 x 40mm	2x			
19	Flat washer, Zinc Plated, M12	4x			
20	Spring Loop Washer Plate	1x			
21	Hex Bolt, Zinc Plated, M14-2.0 x 50mm	1x			
23	Clevis Pin	2x			1x
24	Hairpin Cotter Pin	2x			1x

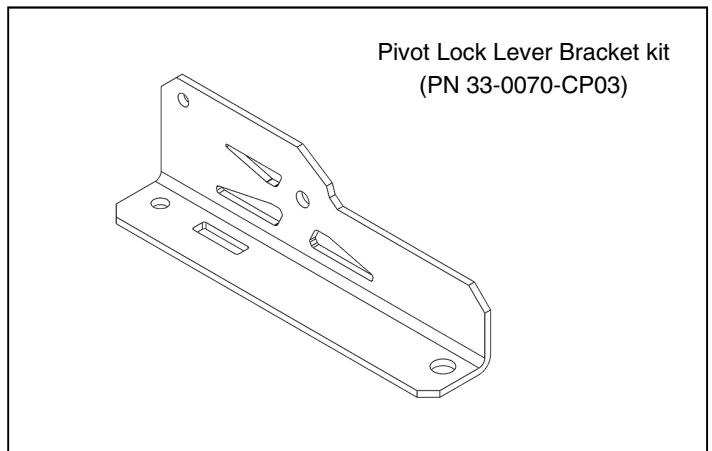
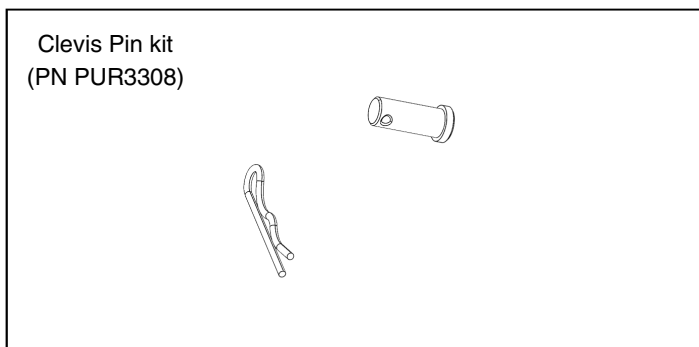
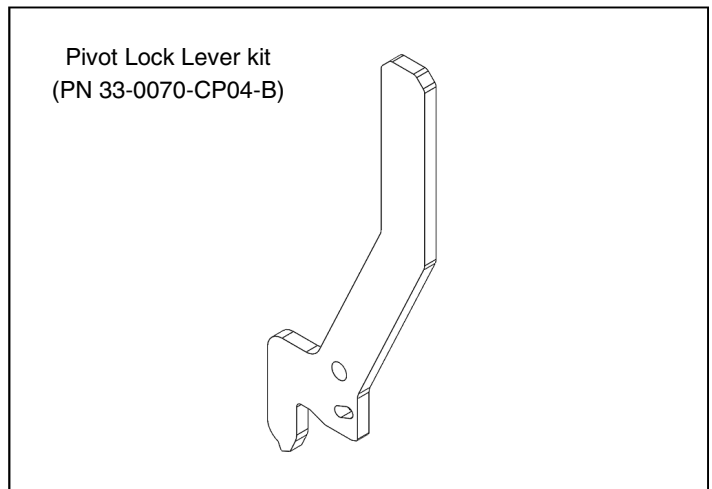
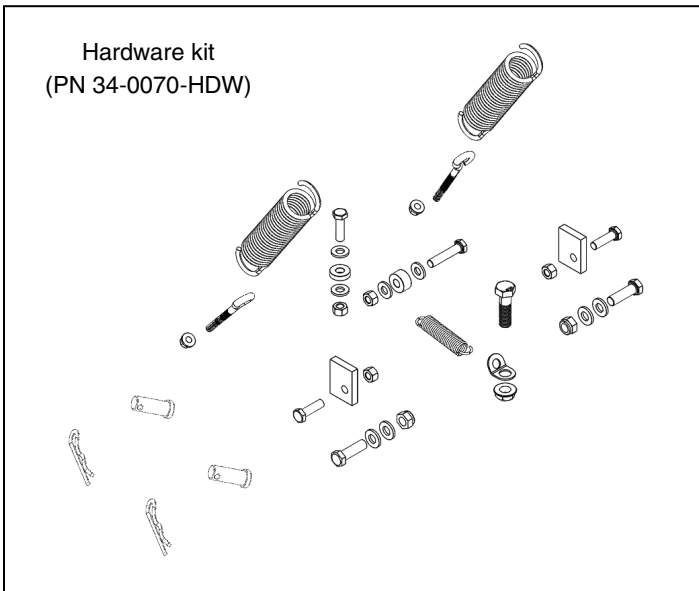

OPERATION:

WINCH CABLE PUSH FRAME LIFT POINT:

1. The winch lift point for the Kolpin push frame is the round hook hole as shown below. (See illustration 4-1)

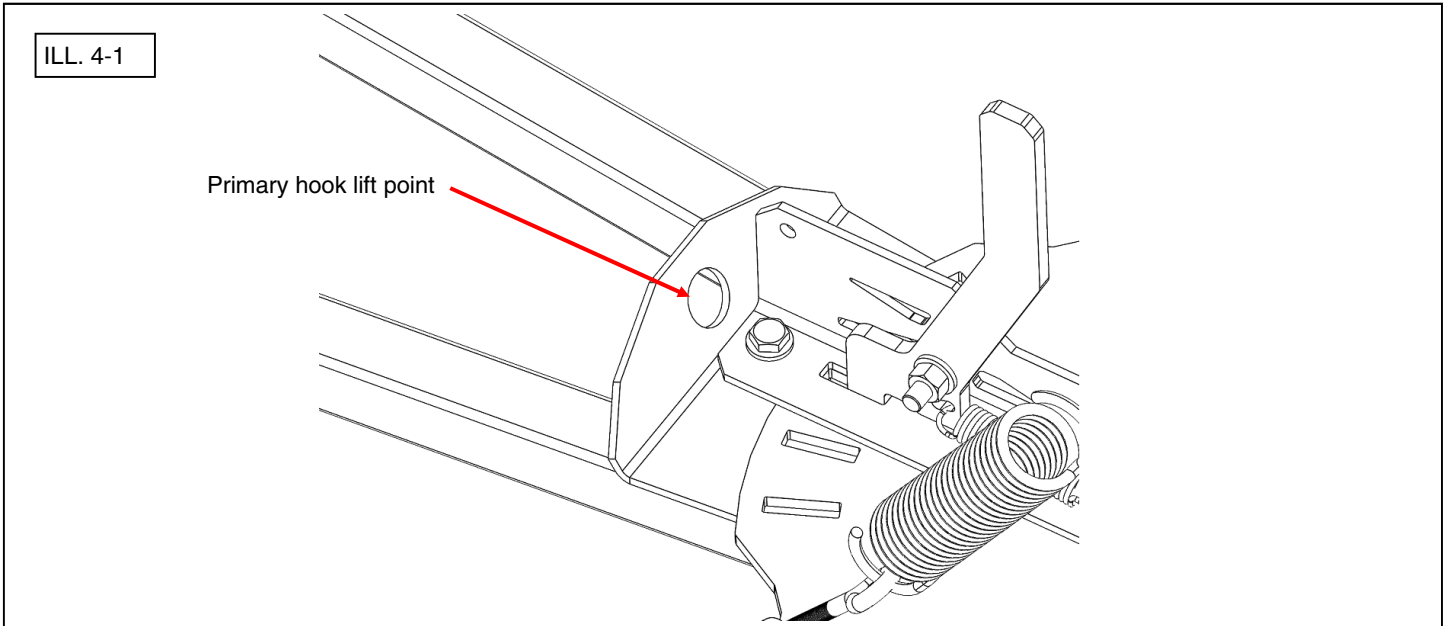

PIVOTING BLADE ANGLE SIDE TO SIDE:

1. To adjust the angle of the plow blade so it pushes to the side, lift the plow up with the lift mechanism to clear the ground. Pull the pivot lock lever toward the blade and swivel the plow to desired angle. Release the pivot lever and the plow will lock itself in place at any of the two angle slot positions on either side. (See illustration 4-2).

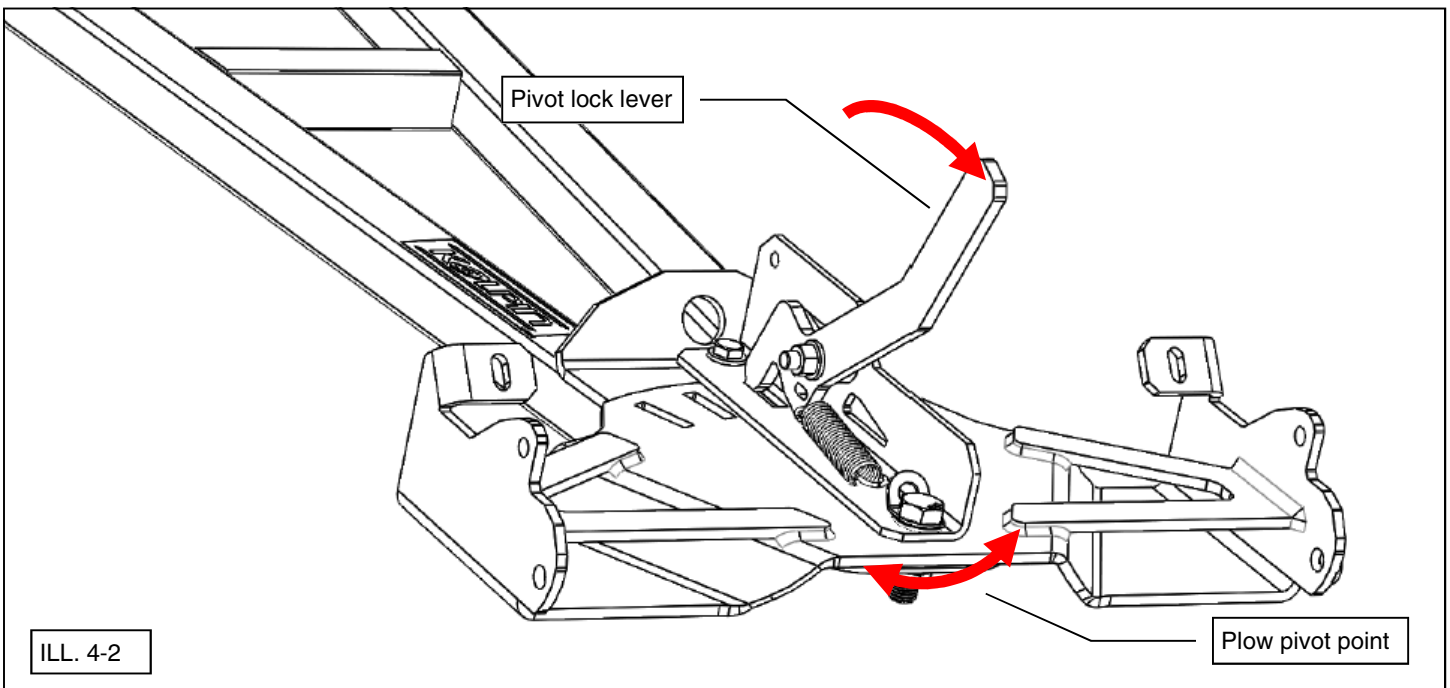

OPERATION (continued):

SCRAPING ANGLE ADJUSTMENT:

1. Turn adjustable plow stoppers to one of the four positions in order to make the plow more aggressive or less aggressive. Position 1 is the position with less material. (See illustrations 4-3 and 4-4)

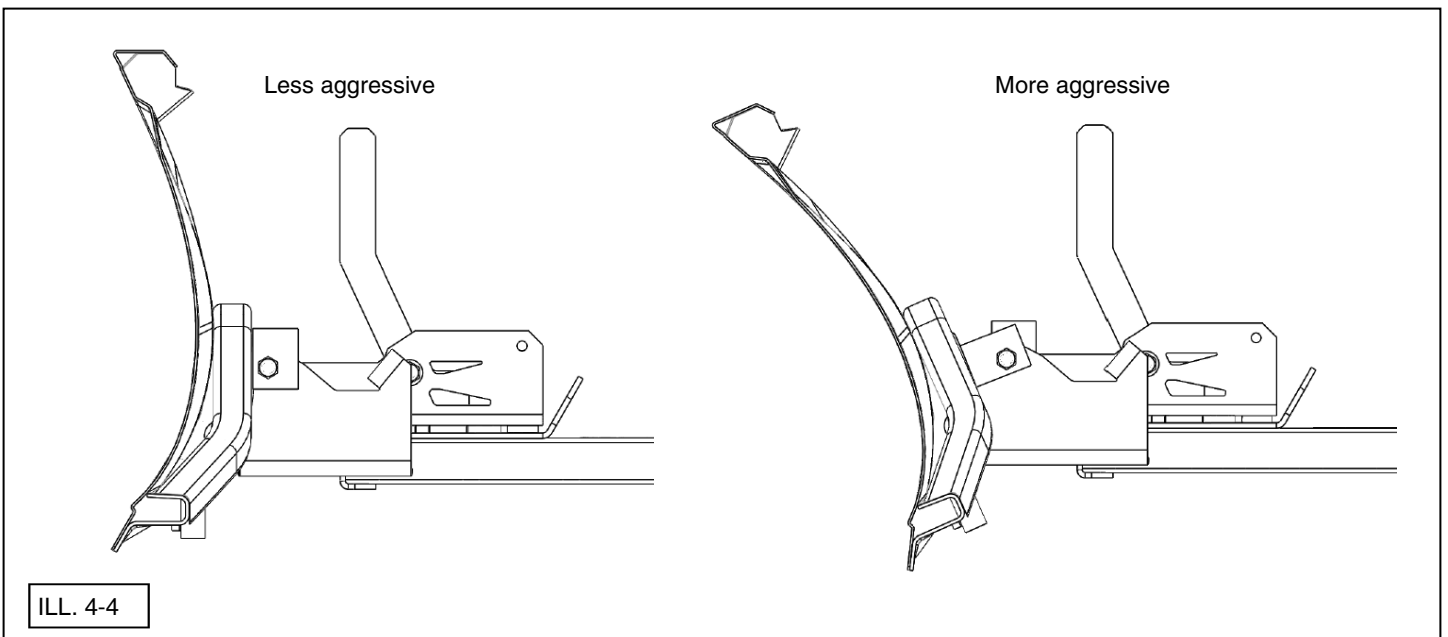
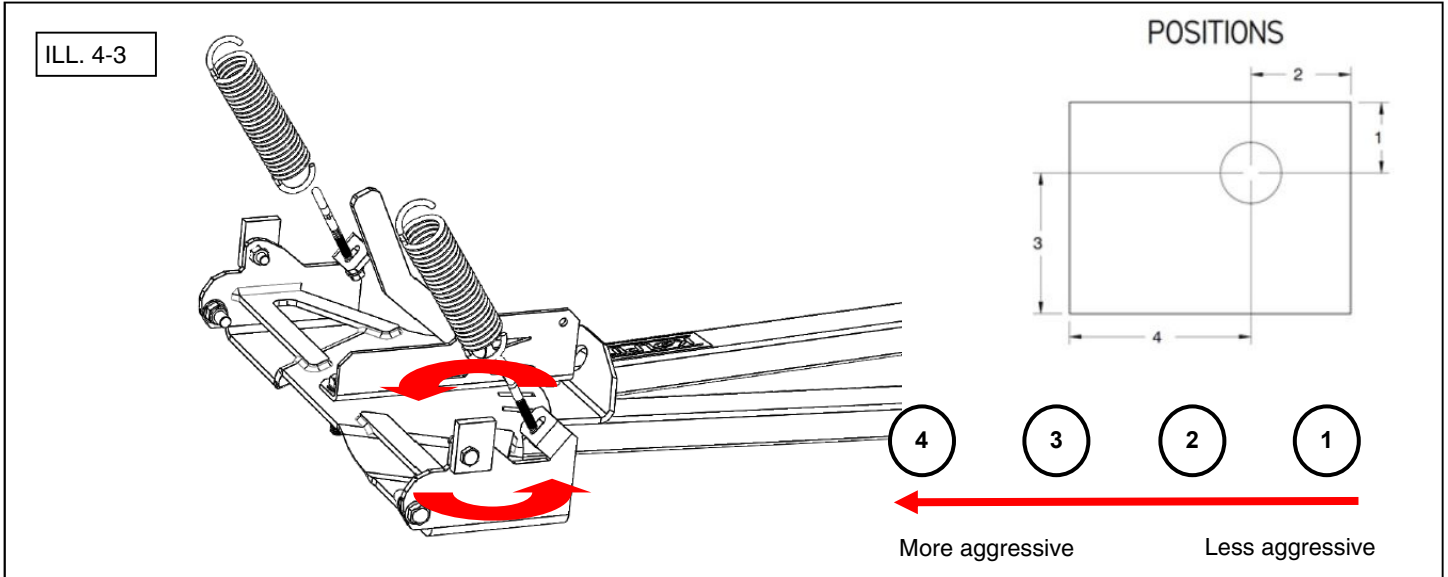

OPERATION (continued):

BLADE TRIP HINGE FUNCTION:

1. The plow is designed to trip forward when it hits a solid object. When the pressure on the plow is released, it will return to its original position by itself. (See illustration 4-5).

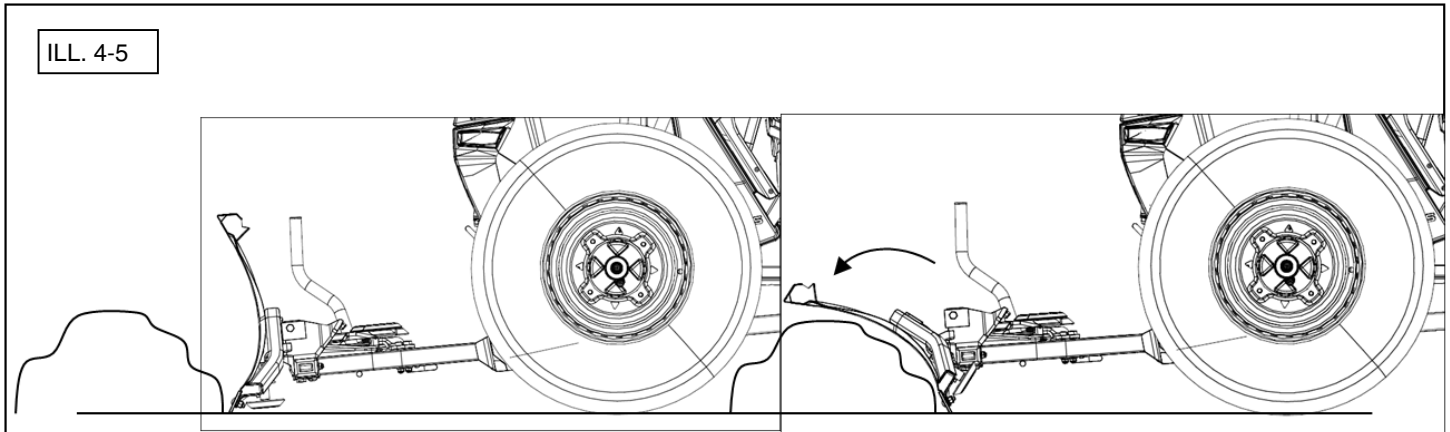

PLOW TRIPPING FORCE ADJUSTMENT:

1. The plow trip springs may be set stiffer by tightening the self-locking nuts located at the ends of the eye bolts. For less tension, loosen the nuts. (See illustration 4-6).

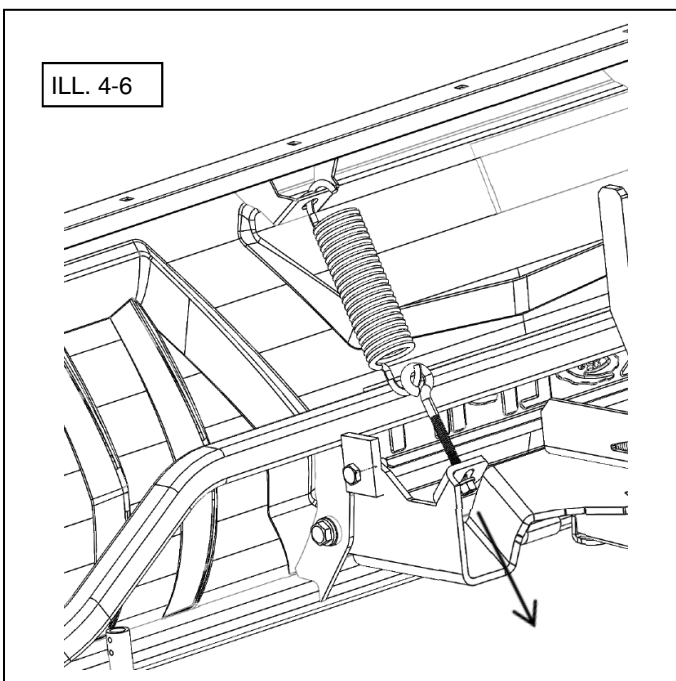

FASTENER TIGHTNESS:

1. Be sure to frequently check that the (5) fasteners of the pivot frame assembly are always tight to ensure good system function. (See illustration 4-7).

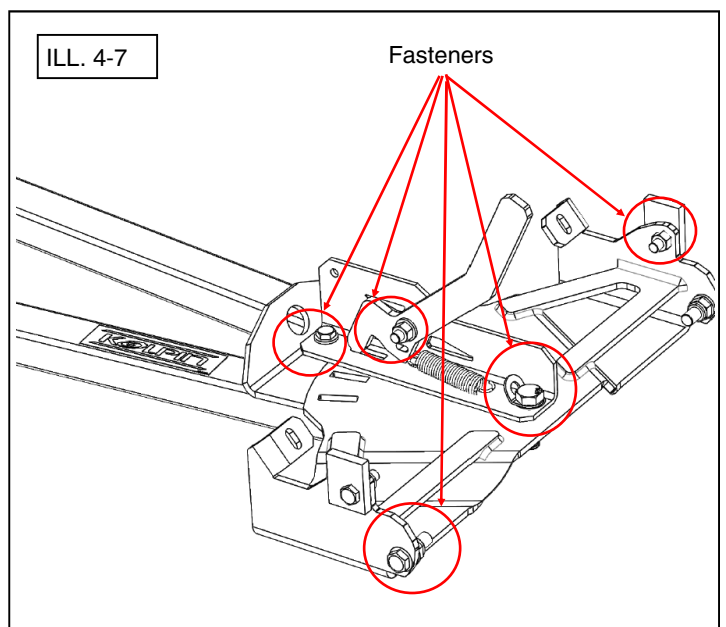



One Year Limited Warranty

For the period of one (1) year from the purchase date, Kolpin will replace for the original purchaser, free of charge, any part or parts found upon examination by Kolpin to be defective in material, workmanship, or both.

All transportation costs incurred submitting product to Kolpin for warranty consideration must be borne by the purchaser. If Kolpin determines that the product must be returned to the factory for credit, please call 1-877-956-5746 for a Return Merchandise Authorization (RMA) number and shipping instructions.

This warranty does not apply to parts that have been damaged by accident, alteration, abuse, improper maintenance, normal wear, or other causes beyond the manufacturer's control. In order to protect you and your ATV, certain parts of the plow system and/or hardware are designed to fail when the equipment is over-stressed. Parts that are lost due to loosening and improper maintenance are not covered under warranty. This warranty does not cover removal or reinstallation labor fees of the plow system and related components.

Peripheral products such as engines, electric motors, and actuators may carry an original manufacturer's warranty. Most hardware is general in nature and is easily obtained locally. Be sure to replace with minimum metric class 8.8 specification.

Kolpin Outdoors, Inc.

Telephone: (763)-478-5800

Toll Free: (877)-956-5746

Fax Number: (800)-245-7569

www.kolpin.com

Email: customerservice@kolpin.com