



ALL MOUNT

ATV PLOW MOUNT KIT

ASSEMBLY / OWNER'S MANUAL

Part No: 15-0050

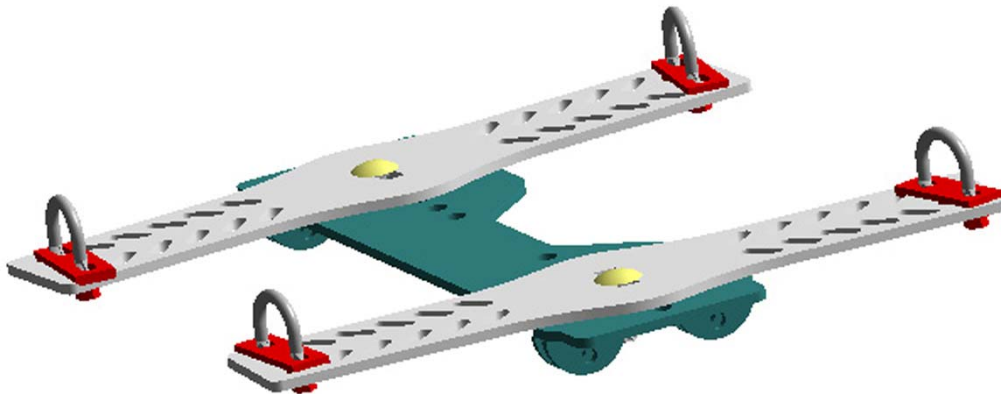

OPERATING INSTRUCTIONS

Congratulations! You've just purchased the most durable plow component in the industry. Our plow systems work great for summer or winter plowing. With proper care and maintenance, your Cycle Country plow system will last for years to come!

NOTICE
Plow operation requires these components: Cycle Country Plow Assembly* Cycle Country Push Tube* Cycle Country Mount Kit* Cycle Country Blade Lift System* (Winch Kit, Electric Lift, Manual Lift)
<small>*These components may be specific to your vehicle. To find your specific application, use the 'Search by Vehicle' function at www.cyclecountry.com</small>

Please read and understand all assembly instructions, notices and warnings before assembling and operating your Cycle Country plow system.

Follow these guidelines to ensure satisfactory operation:

- Read this manual and your ATV operators manual before use.
- Before first use, set plow in the furthest right or left angled position to check for clearance between the plow and front tires.
- Operate with extreme caution on slopes and rough terrain. Be familiar with the area before you plow.
- Be aware of immovable objects that could be hidden in the dirt, gravel or snow you are plowing.
- To avoid damage when plowing dirt, gravel or snow into a pile, reverse direction before raising the plow blade.
- Do not ram the plow blade into piles of dirt, gravel or snow.
- Periodically check for wear and tightness of all fasteners. Replace or re-torque fasteners as necessary.

A complete operator's guide can be downloaded for free at www.cyclecountry.com. This guide contains beginner-to-advanced information regarding plow systems and operation.

SAFETY INFORMATION

Cycle Country plow systems were designed with your safety in mind. In order to protect you and your ATV, certain parts of the plow system and/or hardware are designed to fail when the equipment is over-stressed.

WARNING
To avoid personal injury or damage to your vehicle:
Do not exceed 5 mph (8 kph) with the blade installed
Be aware that vehicle ground clearance is reduced with plow system installed
Keep yourself, other people and pets away from the blade and moving parts during operation
Before adjusting blade angle or disconnecting the plow system, stop the ATV engine and set the parking brake
Remove your plow system before trail riding

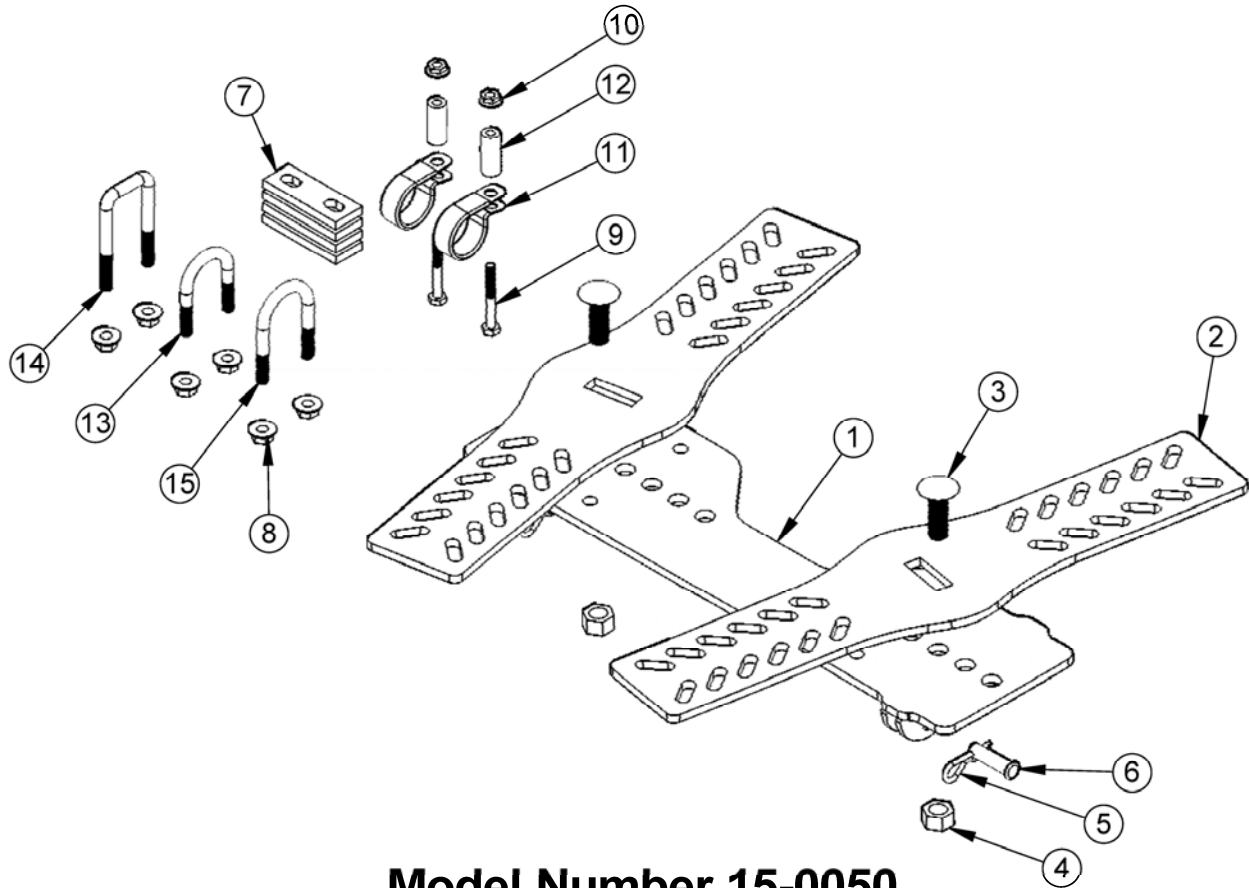

Model Number 15-0050 Parts List

ITEM NO.	QTY.	PART NO.	DESCRIPTION
1	1	CYC4104	Universal Mount Weldment
2	2	CYC4106	Mount Strap
3	2	PUR1176	Carriage Bolt 1/2" x 1-1/2"
4	2	PUR1261	Nut 1/2" Nylock
5	2	PUR1249	#3 Hair Pin
6	2	PUR1209	Clevis Pin .375 x 1.375 Yellow Zinc
7	4	CYC4107	Spacer
8	8	PUR1274	Flange Nut 5/16" Nylock
9	2	PUR1123	1/4" x 2" Bolt
10	2	PUR1264	Nut 1/4" Flange Nylock
11	2	PUR2145	1 1/4" P-Clamp
12	2	PUR1848	Mount Bracket Spacer 1-1/4"
13	4	PUR1419	U-Bolt 5/16" x 1-1/4" x 2"
14	4	PUR1420	5/16" x 1-1/4" x 2-3/4" SQ U-Bolt
15	4	PUR2365	U-Bolt 5/16" x 1-3/8" x 2-7/16"

PARTS ORDERING INFORMATION:

Replacement fasteners are common-type and can be purchased locally.

Use minimum Grade 3 galvanized fasteners.

Standard fastener kit is supplied.

Extra fasteners account for various applications.

ASSEMBLY INSTRUCTIONS:

BEFORE YOU BEGIN:

NOTICE

The ALL Mount is designed to attach to multiple ATV brands. Some items contained in the kit are optional and may not be required to complete the installation.

Frequently check to verify the mount is centered under the ATV, and that the approximate mount set-back distance from the front tire tread is maintained during installation.

CAUTION

Verify any wires, cables, hoses or brake lines are not pinched or damaged during installation.

NOTICE

Install the proper U-bolt for your frame type:

Item #13 = Round Tube Frames (small)

Item #14 = Square Tube Frames

Item #15 = Round Tube Frames (large)

Only 4 U-bolts are required. U-bolts can be installed to the ATV frame front-to-back (Configuration 1), left-to-right (Configuration 2), or a combination of both,

NOTICE

Required Mount Weldment (Item #1)

Set-Back Distance:

34 inches (86.36 cm)

Measurement Locations:

Carriage Bolt to Front of Tire Tread

1. Remove the skid plate from the bottom of the ATV (if equipped).
2. Determine your U-bolt and mounting strap locations. Select from the supplied U-bolts, items #13 or #14 or #15 and pre-fit the mount straps, item #2, to determine the best U-bolts to use, the U-bolt locations on the frame, and the mount set-back distance.

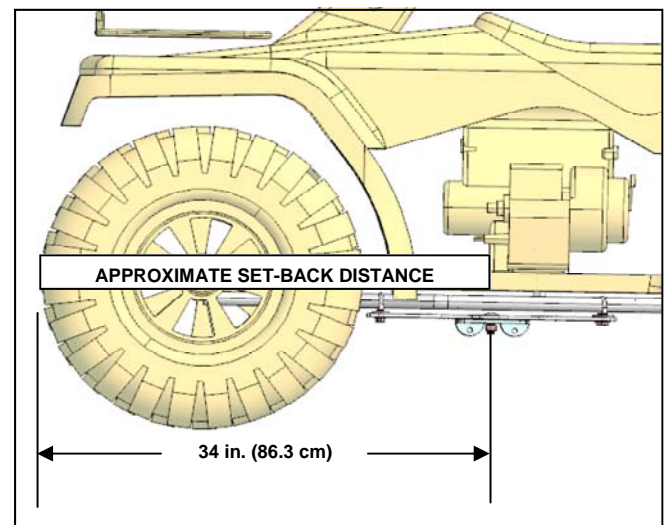
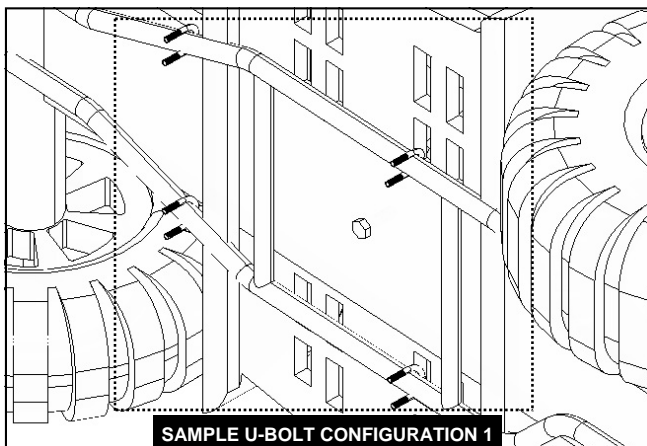
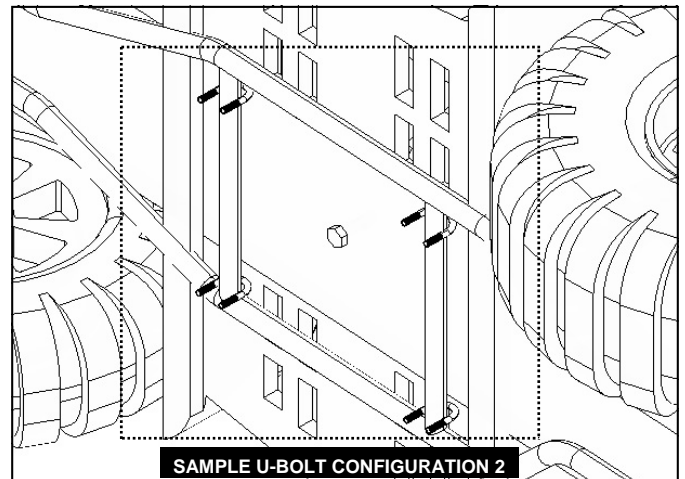

3. Install the selected U-bolts, items #13, #14 or #15 onto the ATV frame rails. See Illustration 1.

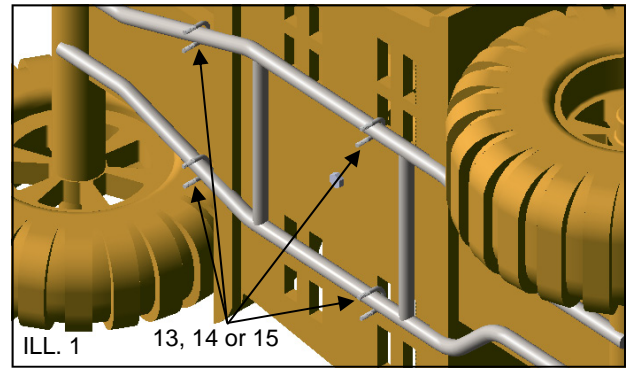

4. If required, place spacers, item #7, onto the U-bolts. See Illustration 2.

NOTICE
Item # 7 spacers are optional and may not be needed on some applications.

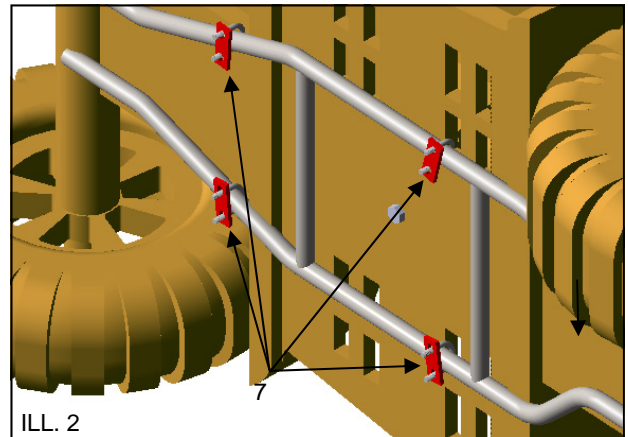

5. Install carriage bolts, item #3 into the center slot of the mount straps, item #2. Mount the assemblies to the U-bolts using fasteners #8. The mount straps must lay flat and should not contact any vehicle components other than their mounting points. *Do not torque the fasteners at this time.* See Illustration 3.

NOTICE
Item # 7 spacers may be needed on some applications.

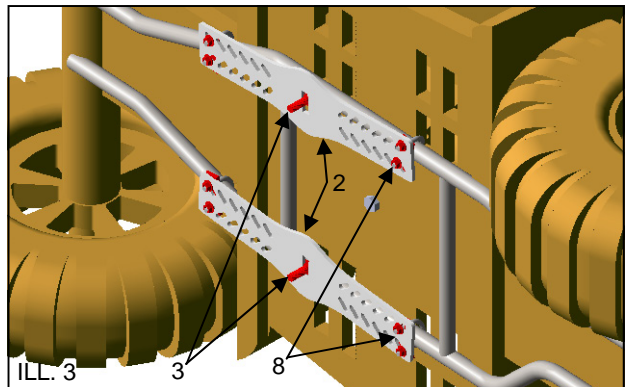

6. Attach universal mount weldment, item #1 using fastener items #4 as shown in Illustration 4. *Do not torque the fasteners at this time.*

NOTICE
Universal mount cutout can be oriented forward or backward to add clearance for drain plugs (arrow)

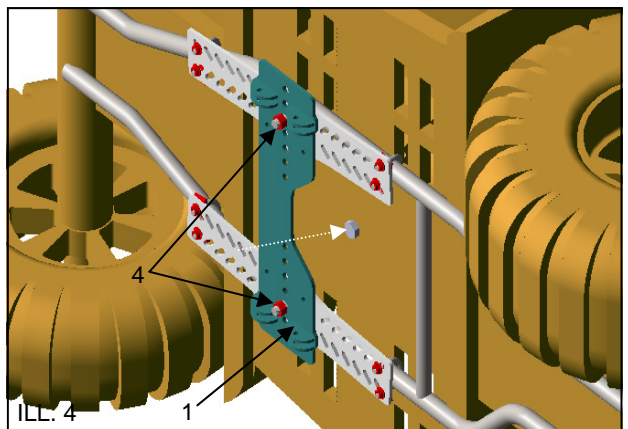

- Verify the universal mount is centered under the ATV and achieves the approximate set-back measurement in Illustration 5. *Due to variations among vehicle frames, tire size, etc. achieving an approximate set-back measurement is acceptable. Tires must not rub the plow blade when it is mounted and angled.*

NOTICE
Universal Mount Weldment (Item #1)
Set-Back Distance:
34 inches (86.36 cm)
Carriage Bolt to Front of Tire Tread

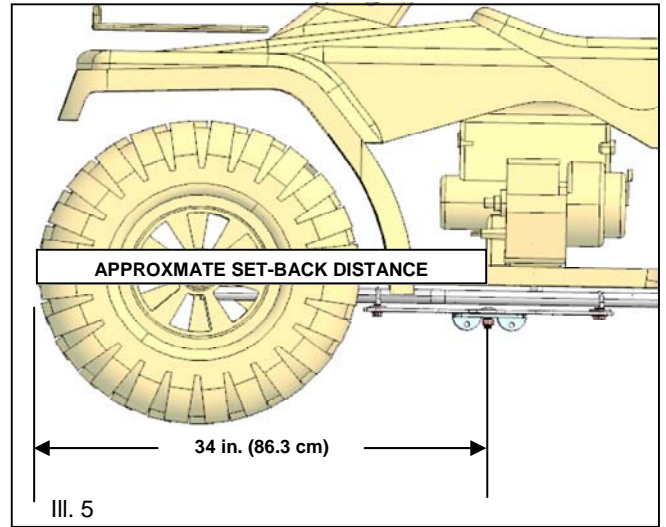

- Torque the U-bolt fasteners, item #8 to specification.

 = T
U-BOLT FASTENER TORQUE:
17ft. lbs. (23 Nm)

- Torque the universal mount fasteners, item #4 to specification.

 = T
UNIVERSAL MOUNT FASTENER TORQUE:
30 ft. lbs. (41 Nm)

- Assemble and attach push tube using items #5 as shown in Illustration 5. Secure with hair pins #6. See Illustration 6.

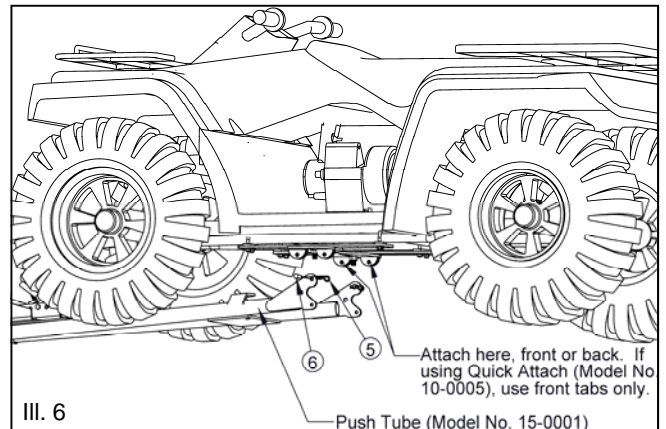

- OPTIONAL** - Items #9, #10, #11, and #12 can be used to reattach the front inner fenders as a result of skid plate removal in Step 1. See Illustration 7.

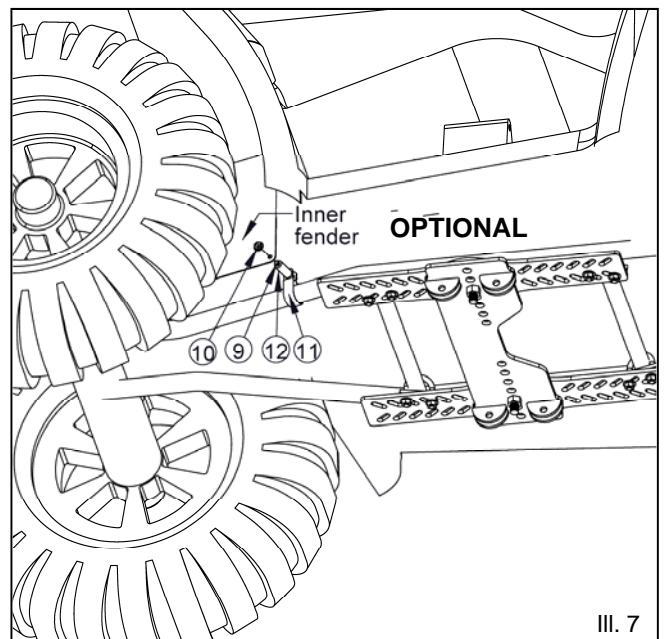



One Year Limited Warranty

For the period of one (1) year from the purchase date, Cycle Country Accessories Corporation will replace for the original purchaser, free of charge, any part or parts found upon examination by Cycle Country Accessories Corporation to be defective in material, workmanship, or both.

All transportation costs incurred submitting product to Cycle Country for warranty consideration must be borne by the purchaser. If Cycle Country determines that the product must be returned to the factory for credit, please call 1-800-841-2222 for a Return Merchandise Authorization (RMA) number and shipping instructions.

This warranty does not apply to parts that have been damaged by accident, alteration, abuse, improper maintenance, normal wear, or other causes beyond the manufacturer's control. In order to protect you and your ATV, certain parts of the plow system and/or hardware are designed to fail when the equipment is over-stressed. For this reason, push tubes, blade hinges, mounting brackets and clevis pins are not covered under warranty.

Peripheral products such as engines, electric motors, and actuators may carry an original manufacturer's warranty. Please call Cycle Country Accessories Corporation for more information.

CYCLE COUNTRY ACCESSORIES CORPORATION

1761 38TH AVE W

PO BOX 267

SPENCER, IA 51301

SERVICE: 800-841-2222

FAX: 712-262-0248

E-MAIL: ccao@oyoleocountry.com

WEB: www.oyoleocountry.com

© 2010 Cycle Country Accessories Corporation

**SALES PROMO
PAGE**