



DRIVE IN X-CHANGE™

PUSH TUBE ADAPTER Patent Pending - Universal

ASSEMBLY / OWNER'S MANUAL

Part No: 15-0150

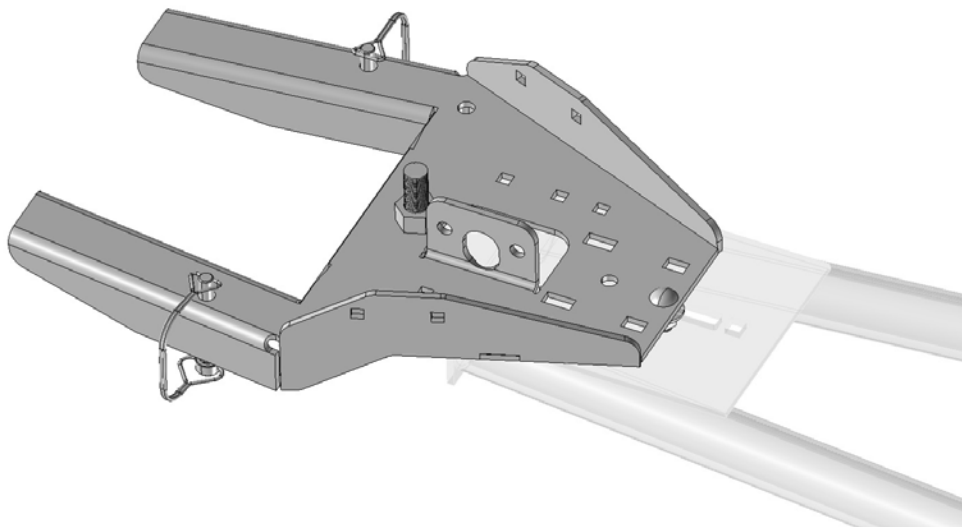

OPERATING INSTRUCTIONS

Congratulations! You've just purchased the most durable accessory component in the industry. Cycle Country accessories work great summer or winter. With proper care and maintenance, your Cycle Country accessory will last for years to come!

NOTICE
<p>The Drive In X-Change™ system requires a Push Tube Adapter and one or more of these components to fully function:</p> <ul style="list-style-type: none">• Quick Attach Blade• Drive In X-Change™ Accessories

NOTICE
<p>The Drive In X-Change™ Push Tube Adapter is <u>not</u> compatible with these products:</p> <ul style="list-style-type: none">• ARM Plow 10-0300• ARM Plow 10-0350• Snow Force 18-0030

Please read and understand all assembly instructions, notices and warnings before assembling and operating your accessory.

Follow these guidelines to ensure satisfactory operation:

- Periodically check for wear and tightness of all fasteners. Replace or re-torque fasteners as necessary.
- For best results, use with a winch system or a PowerMax Electric Lift. Attach lifting mechanism to the Push Tube Adapter only.
- Read this manual and your ATV operators manual before use.

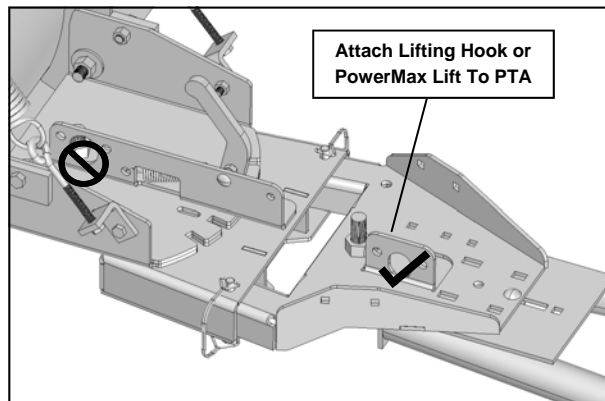

SAFETY INFORMATION

Cycle Country accessories were designed with your safety in mind. In order to protect you and your vehicle, certain parts of the accessory and/or hardware may be designed to fail when the equipment is over-stressed.

 WARNING
<p>To avoid personal injury or damage to your vehicle:</p> <p>Read and understand all cautions, warnings, notices, and instructions</p> <p>Do not carry unsecured loads at any time</p> <p>Do not exceed the load capacity of the winch or lift. Refer to the owner's manual.</p> <p>Keep yourself, other people and pets away from moving parts during operation</p> <p>Exercise caution during operation to avoid pinch hazard</p>

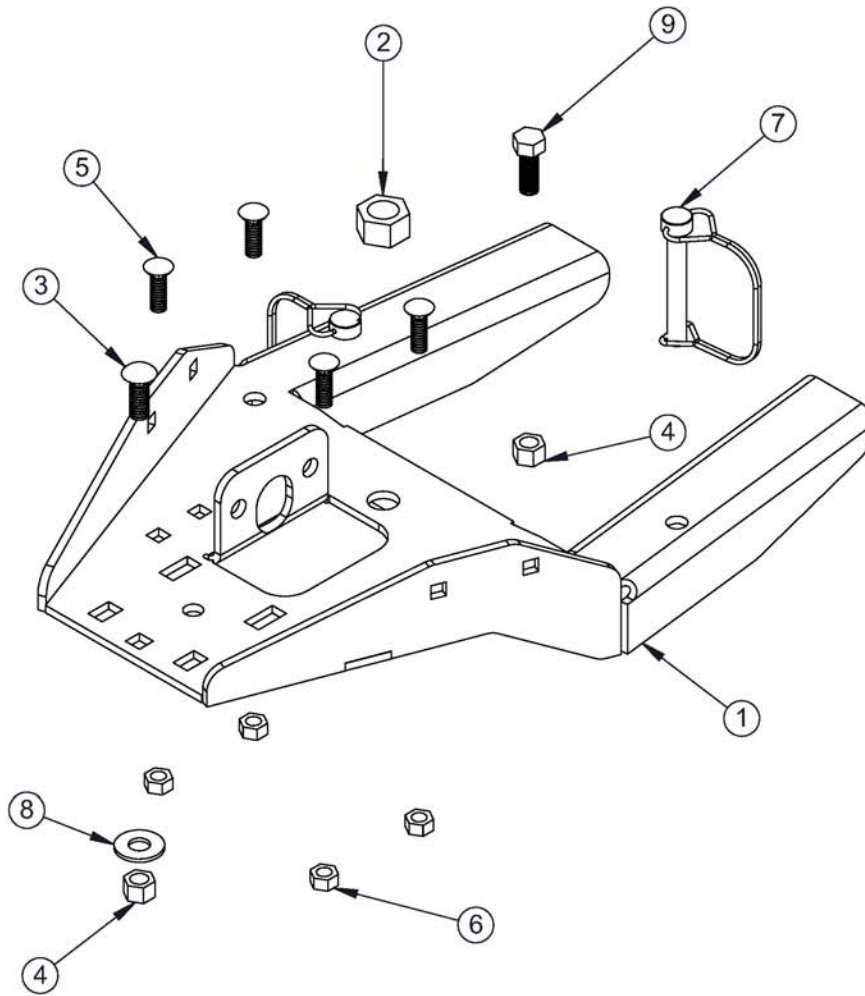

Model Number 15-0150 Parts List

ITEM NO.	QTY.	PART NO.	DESCRIPTION
1	1	CYC6032	PTA Weldment Universal
2	1	PUR1283	Locknut 5/8" Nylock
3	1	PUR1185	Carriage Bolt 3/8" x 1"
4	2	PUR1272	Locknut 3/8" Nylock
5	4	PUR1189	Carriage Bolt 5/16" x 1" Clear Zinc
6	4	PUR1275	Locknut 5/16" Nylock Clear Zinc
7	2	PUR1286	3/8" x 2 1/2" Lock Pin
8	1	PUR1243	3/8" Flatwasher
9	1	PUR1140	3/8" x 1" Bolt

PARTS INFORMATION:

Replacement fasteners are common-type and can be purchased locally. Use minimum Grade 5 zinc-coated fasteners. Some fasteners may not be used depending on application. Refer to the assembly instructions.

BEFORE YOU BEGIN:

- Please read and understand all instructions.
- Verify all parts and tools are accounted for.
- To ensure a satisfactory installation, follow all steps correctly and in the sequence described.
- All directions referring to right and left are when the rider is sitting on the machine

TOOLS REQUIRED:

- Basic Hand Wrench and Socket Set
- Torque Wrench
- Hex Wrench Set

PUSH TUBE ADAPTER INSTALLATION CYCLE COUNTRY:

1. If not already disassembled, remove the hinge plate assembly from the push tube. See Illustration 1.

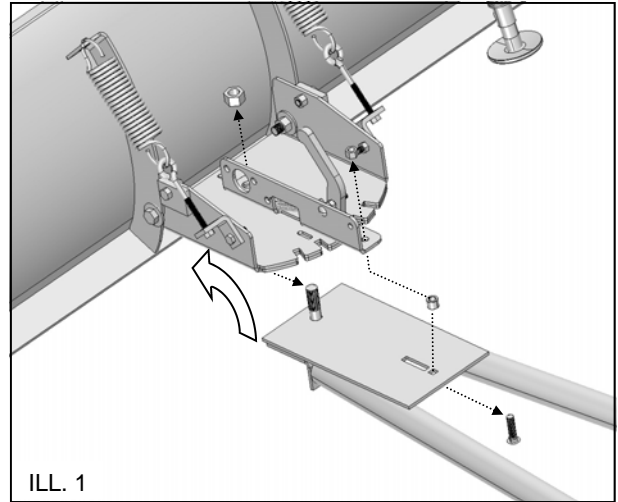

2. Place the PTA Weldment, Item #1, onto the push tube. Fasten forward portion of the PTA with lock nut, Item #2. Fasten rear portion of the PTA with carriage bolt, Item #3, washer, Item #8 and lock nut, Item #4. See Illustration 2.

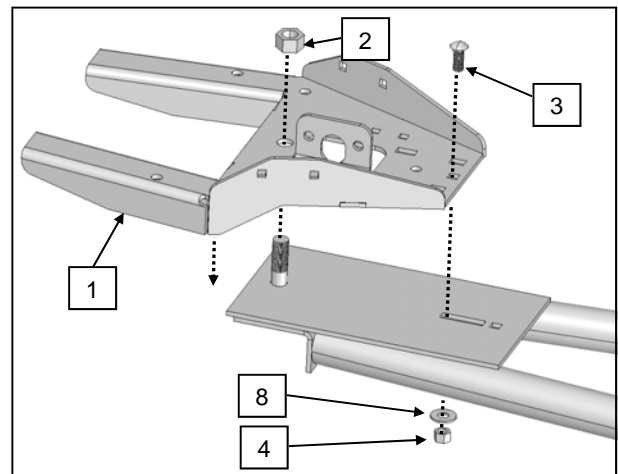

3. Torque fasteners to specification.

 = T
FASTENER TORQUE:
Item #4 - 30ft. lbs. (40.6 Nm)
Item #2 - 95ft. lbs. (128.8 Nm)

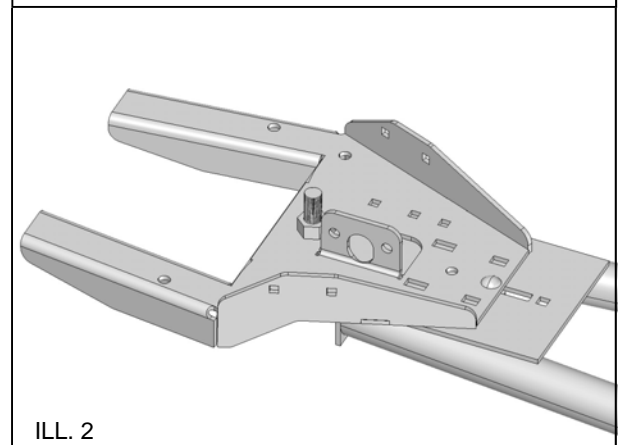

PUSH TUBE ADAPTER INSTALLATION EAGLE - Front and Mid-Mount Models:

1. If not already disassembled, remove the hinge plate assembly from the push tube. Retain Fasteners.
2. Place the PTA Weldment, Item #1, onto the push tube. Fasten forward portion of the PTA with the bolt, washers and lock nut retained from the push tube disassembly. See Illustration 3.
3. Fasten rear portion of the PTA with carriage bolts, Item #5 and lock nuts, Item #6. See Illustration 3. Torque all fasteners to specification.

 = T
FASTENER TORQUE: Item #6 - 17ft. lbs. (23 Nm) Supplied Bolt / Lock Nut - 95ft. lbs. (128.8 Nm)

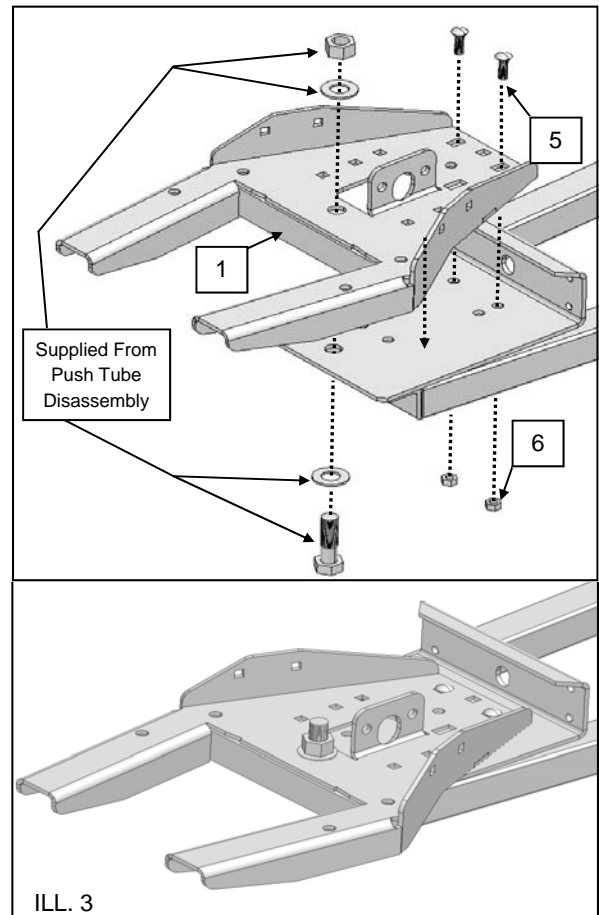

PUSH TUBE ADAPTER INSTALLATION MOOSE - M93 and RM4 Models:

1. If not already disassembled, remove the hinge plate assembly from the push tube. Retain Fasteners.
2. Place the PTA Weldment, Item #1, onto the push tube, sliding it under the welded tab as shown. Fasten forward portion of the PTA with the bolt and lock nut retained from the push tube disassembly. See Illustration 4.
3. Fasten rear portion of the PTA with carriage bolts, Item #5 and lock nuts, Item #6. See Illustration 4. Torque all fasteners to specification.

 = T
FASTENER TORQUE: Item #6 - 17ft. lbs. (23 Nm) Supplied Bolt / Lock Nut - 30ft. lbs. (40.6 Nm)

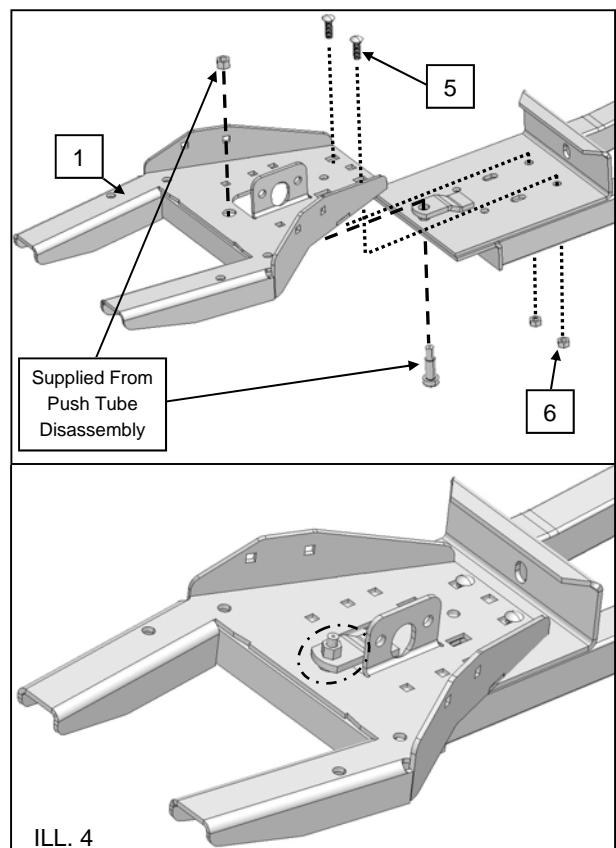

PUSH TUBE ADAPTER INSTALLATION MOOSE - RM3 Model:

1. If not already disassembled, remove the hinge plate assembly from the push tube. Retain Fastener.
2. Place the PTA Weldment, Item #1, onto the push tube as shown. Fasten forward portion of the PTA with lock nut retained from the push tube disassembly. See Illustration 5.
3. Fasten rear portion of the PTA with carriage bolts, Item #5 and lock nuts, Item #6. See Illustration 5. Torque all fasteners to specification.

 = T
FASTENER TORQUE: Item #6 - 17ft. lbs. (23 Nm) Supplied Lock Nut - 95ft. lbs. (128.8 Nm)

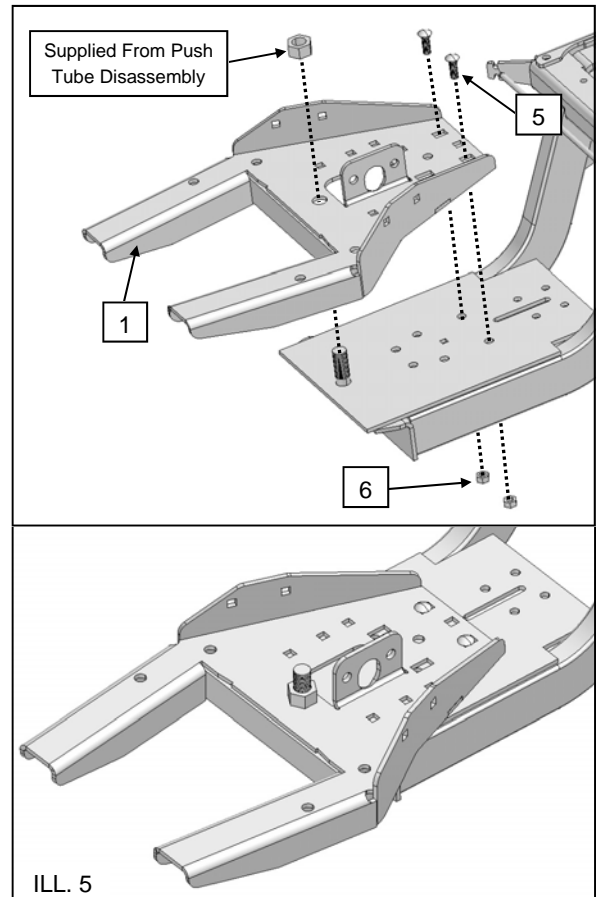

PUSH TUBE ADAPTER INSTALLATION POLARIS - Glacier II Model:

1. If not already disassembled, remove the hinge plate assembly from the push tube. Retain Fasteners.
2. Place the PTA Weldment, Item #1, onto the push tube. Fasten forward portion of the PTA with the bolt, washers and lock nut retained from the push tube disassembly. See Illustration 6.
3. Fasten rear portion of the PTA with carriage bolts, Item #5 and lock nuts, Item #6. See Illustration 6. Torque all fasteners to specification.

 = T
FASTENER TORQUE: Item #6 - 17ft. lbs. (23 Nm) Supplied Bolt / Lock Nut - 95ft. lbs. (128.8 Nm)

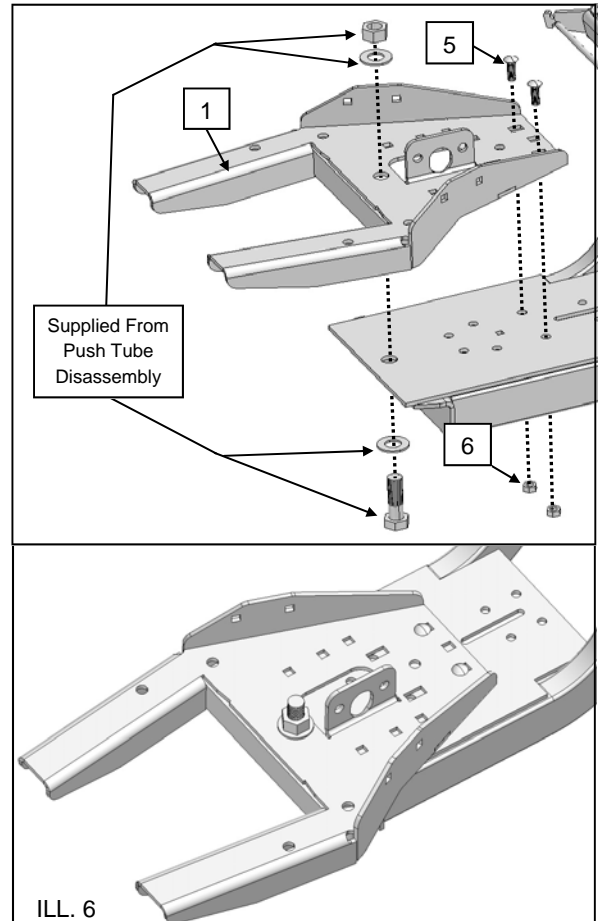

PUSH TUBE ADAPTER INSTALLATION

WARN - Front Mount Model:

1. If not already disassembled, remove the hinge plate assembly from the push tube.
2. Place the PTA Weldment, Item #1, onto the push tube. Install fasteners, Items #5 and #6, in mount holes as shown. See Illustration 7.
3. Torque fasteners to specification.

 = T
FASTENER TORQUE: Item #6 - 17ft. lbs. (23 Nm)

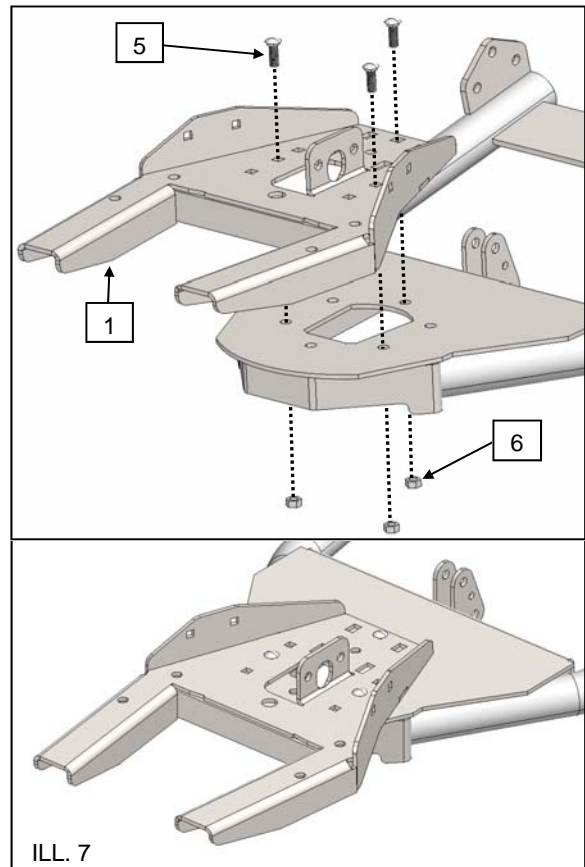

PUSH TUBE ADAPTER INSTALLATION

WARN - Mid-Mount Model:

1. If not already disassembled, remove the hinge plate assembly from the push tube.
2. Place the PTA Weldment, Item #1, onto the push tube. Place washer, Item #8 over the front hole and fasten with bolt, Item #9 and lock nut, Item #4. See Illustration 8.
3. Install fasteners, Items #5 and #6, in remaining mount holes. NOTE: rear hole is not used. See Illustration 8.
4. Torque fasteners to specification.

 = T
FASTENER TORQUE: Item #6 - 17ft. lbs. (23 Nm) Item #4 - 30ft. lbs. (40.6 Nm)

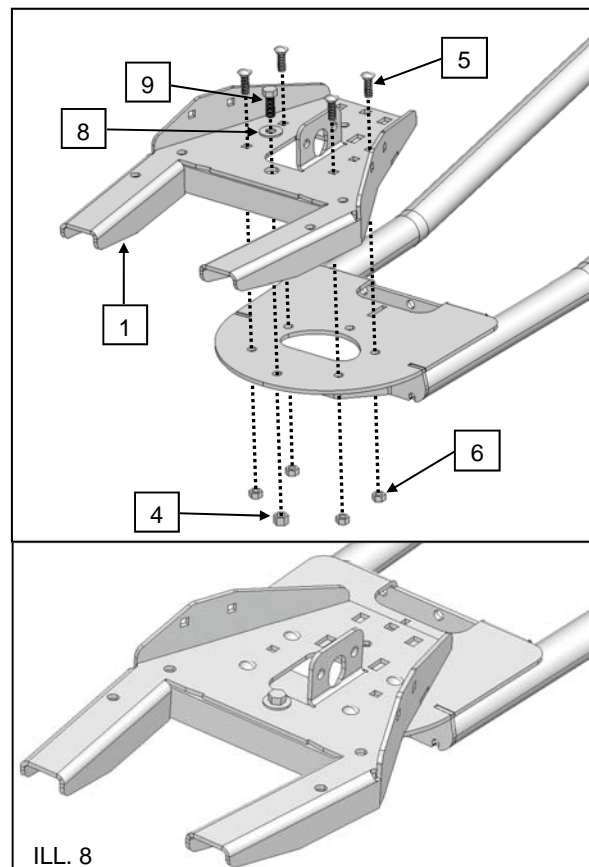

PUSH TUBE ADAPTER ENGAGEMENT:

1. Drive machine forward while directing the PTA forks into the attachment. **NOTE:** *It may be necessary to lift the push tube slightly during engagement.*
2. Lift the attachment off the ground and verify the lock pin holes are aligned.

NOTICE

Stop engine and lock parking brake
before dismounting the ATV to install lock pins

3. Insert lock pins, Item #7. See Illustration 9.
NOTE: *Recommended lock pin installation is from the bottom side for easier removal and reduces the chance of catching on obstacles.*
4. Attach winch hook or PowerMax Electric Lift to the PTA. See Illustration 9.
5. To disengage from the attachment, raise the push tube and remove the lock pins. Lower the push tube to the ground and back the machine away, pulling the PTA forks out of the attachment.

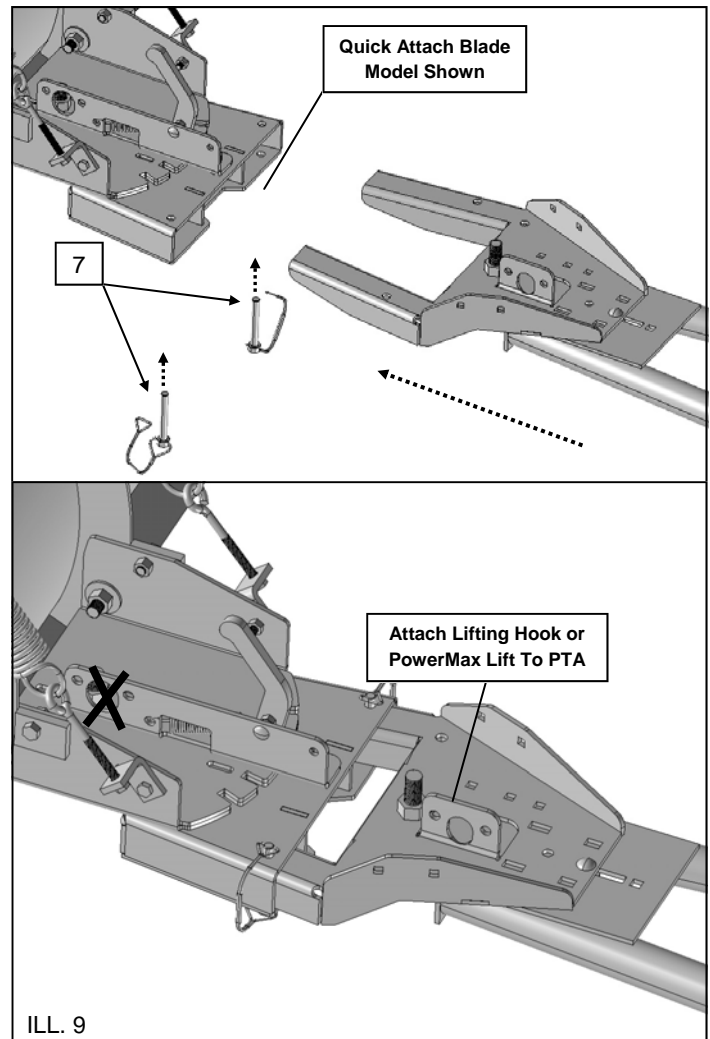



One Year Limited Warranty

For the period of one (1) year from the purchase date, Cycle Country Accessories Corporation will replace for the original purchaser, free of charge, any part or parts found upon examination by Cycle Country Accessories Corporation to be defective in material, workmanship, or both.

All transportation costs incurred submitting product to Cycle Country for warranty consideration must be borne by the purchaser. If Cycle Country determines that the product must be returned to the factory for credit, please call 1-800-841-2222 for a Return Merchandise Authorization (RMA) number and shipping instructions.

This warranty does not apply to parts that have been damaged by accident, alteration, abuse, improper maintenance, normal wear, or other causes beyond the manufacturer's control. In order to protect you and your ATV, certain parts of the plow system and/or hardware are designed to fail when the equipment is over-stressed.

Peripheral products such as engines, electric motors, and actuators may carry an original manufacturer's warranty. Please call Cycle Country Accessories Corporation for more information.

CYCLE COUNTRY ACCESSORIES CORPORATION

1701 38TH AVE W

SPENCER, IA 51301

SERVICE: 800-841-2222 FAX: 712-262-0248

E-MAIL: ccac@cyclecountry.com

WEB: www.cyclecountry.com