



# DRIVE IN X-CHANGE™

SIMPLEMENT Patent Pending - Trash Can Shuttle

## ASSEMBLY / OWNER'S MANUAL

Part No: 15-0200

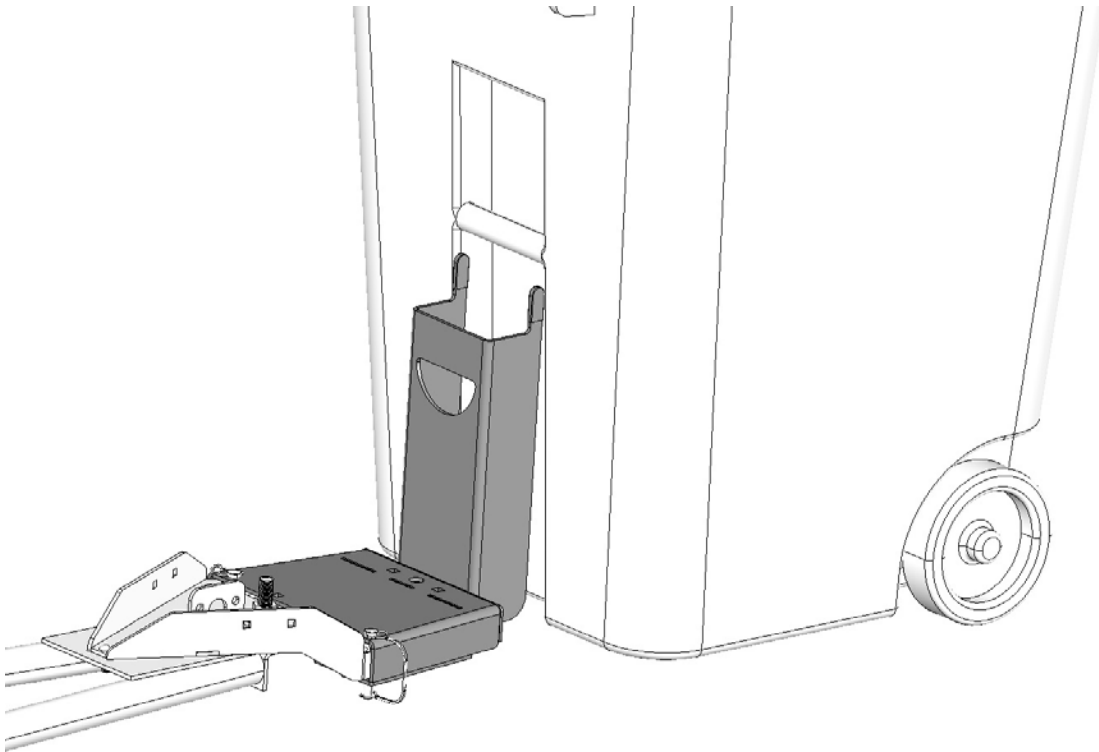

# OPERATING INSTRUCTIONS

Congratulations! You've just purchased the most durable accessory component in the industry. Cycle Country accessories work great summer or winter. With proper care and maintenance, your Cycle Country accessory will last for years to come!

NOTICE
<p>The Drive In X-Change™ system requires a Simplement Trash Can Shuttle and one or more of these components to fully function:</p> <ul style="list-style-type: none"><li>• Push Tube Adapter</li><li>• Drive In X-Change™ Accessories</li></ul>

Please read and understand all assembly instructions, notices and warnings before assembling and operating your accessory.

## Follow these guidelines to ensure satisfactory operation:

- Periodically check for wear and tightness of all fasteners. Replace or re-torque fasteners as necessary.
- For best results, use with a winch system or a PowerMax Electric Lift. Attach lifting mechanism to the Push Tube Adapter only.
- Read this manual and your ATV operators manual before use.
- Trash can total weight should not exceed 75 lbs. (34.01 Kg).

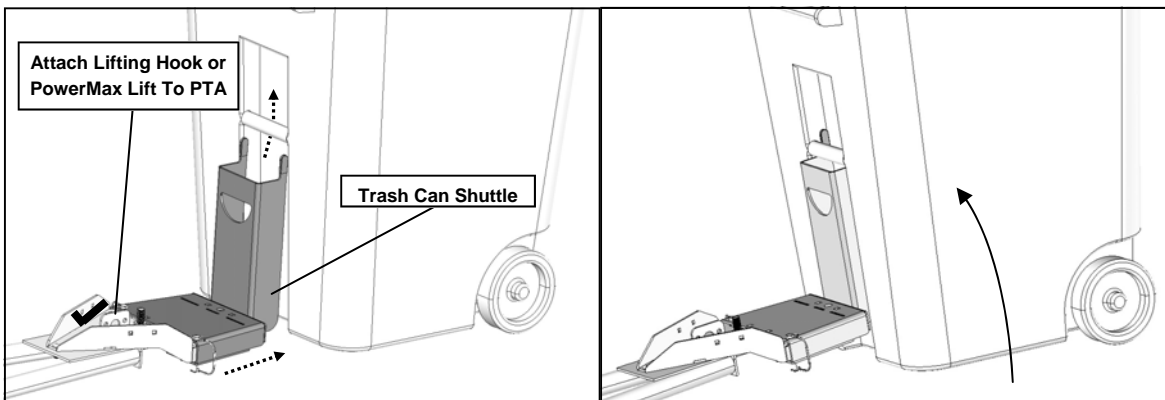

# SAFETY INFORMATION

Cycle Country accessories were designed with your safety in mind. In order to protect you and your vehicle, certain parts of the accessory and/or hardware may be designed to fail when the equipment is over-stressed.

 <b>WARNING</b>
<p><b>To avoid personal injury or damage to your vehicle:</b></p> <p>Do not exceed 75 lbs. (34.01 Kg) total lifting weight.</p>

 <b>WARNING</b>
<p><b>To avoid personal injury or damage to your vehicle:</b></p> <p>Read and understand all cautions, warnings, notices, and instructions</p> <p>Do not carry unsecured loads at any time</p> <p>Do not exceed the load capacity of the winch or lift. Refer to the owner's manual.</p> <p>Keep yourself, other people and pets away from moving parts during operation</p> <p>Exercise caution during operation to avoid pinch hazard</p>

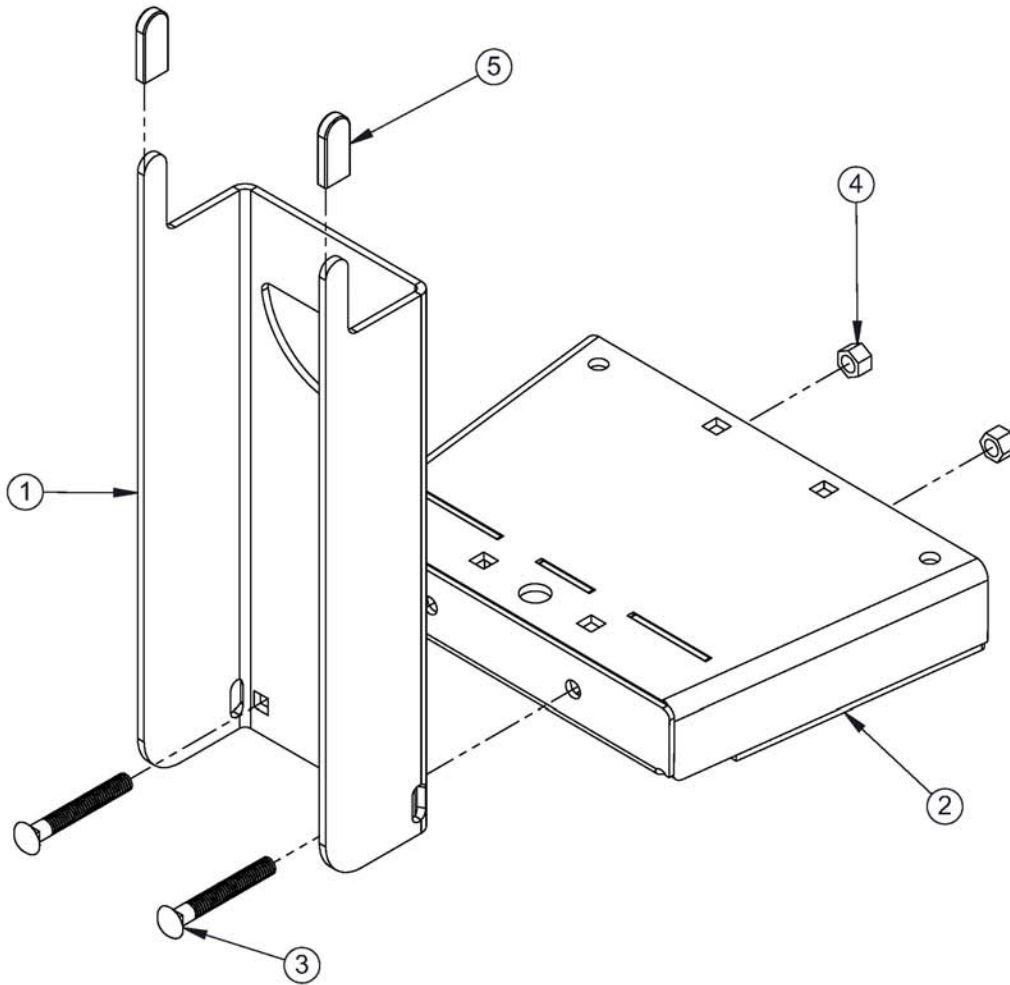

## Model Number 15-0200 Parts List

ITEM NO.	QTY.	PART NO.	DESCRIPTION
1	1	CYC6104	Attaching Bracket
2	1	CYC6056	SAM Receiver Weldment
3	2	PUR0696	Carriage Bolt 3/8" x 2 3/4"
4	2	PUR1272	Locknut 3/8" Nylock
5	2	PUR2393	.625" x .1875" x 1.5" vinyl cap

**PARTS INFORMATION:**  
 Replacement fasteners are common-type and can be purchased locally. Use minimum Grade 5 zinc-coated fasteners.

## BEFORE YOU BEGIN:

- Please read and understand all instructions.
- Verify all parts and tools are accounted for.
- To ensure a satisfactory installation, follow all steps correctly and in the sequence described.
- All directions referring to right and left are when the rider is sitting on the machine

## TOOLS REQUIRED:

- Basic Hand Wrench and Socket Set
- Torque Wrench

## BALL HITCH RECIEVER ASSEMBLY:

1. Place the attaching bracket, Item #1, onto the SAM weldment, Item #2. See Illustration 1.
2. Insert fasteners, Items #3 and #4, as shown. Torque fasteners to specification. See Illustration 1.

 = T
<b>FASTENER TORQUE:</b> 30 ft. lbs. (40.6 Nm)

3. Attach vinyl caps, Item #5. See Illustration 1.

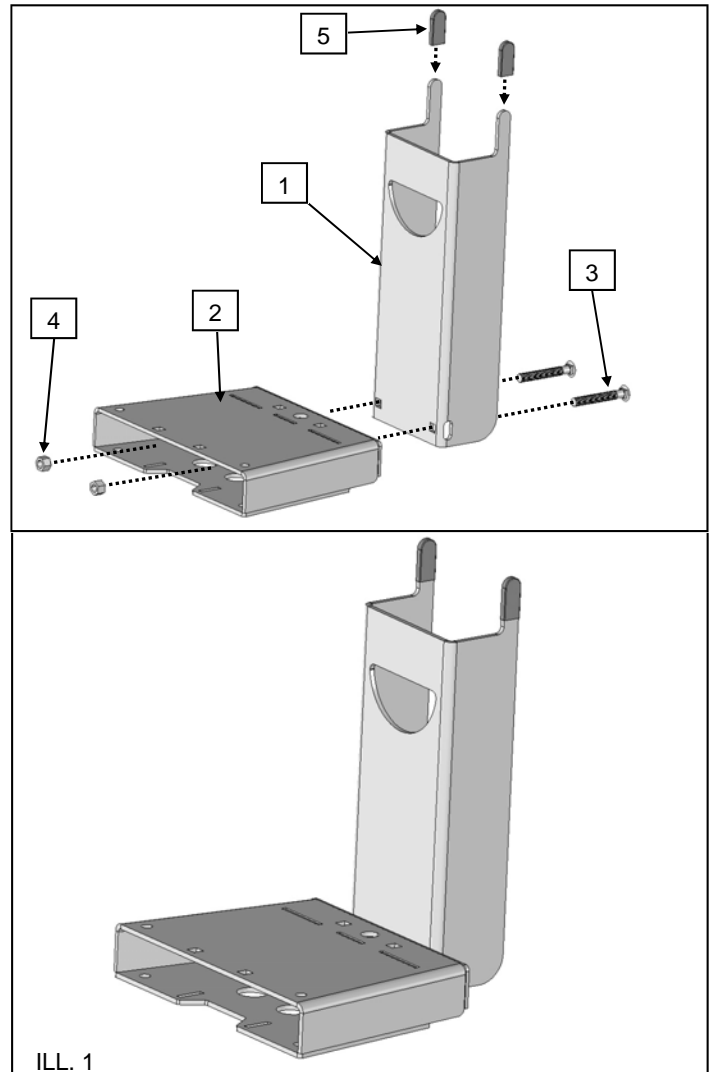

## PUSH TUBE ADAPTER ENGAGEMENT:

1. Direct the attachment onto the PTA forks.
2. Verify the lock pin holes are aligned.
3. Insert lock pins. See Illustration 3.  
**NOTE:** Recommended lock pin installation is from the bottom side for easier removal and reduces the chance of catching on obstacles.

NOTICE
Stop engine and lock parking brake before dismounting the ATV to install lock pins

4. Attach winch hook or PowerMax Electric Lift to the PTA. See Illustration 3.
5. To disengage the attachment, raise the push tube and remove the lock pins. Pull the attachment off the PTA forks.

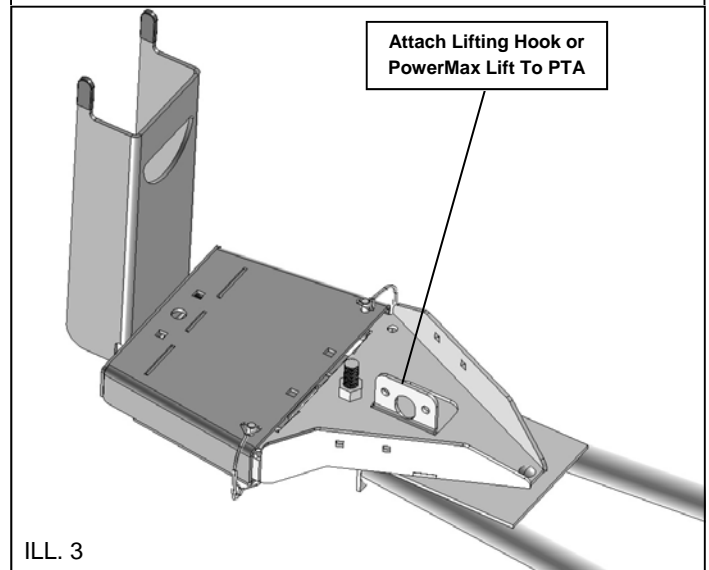
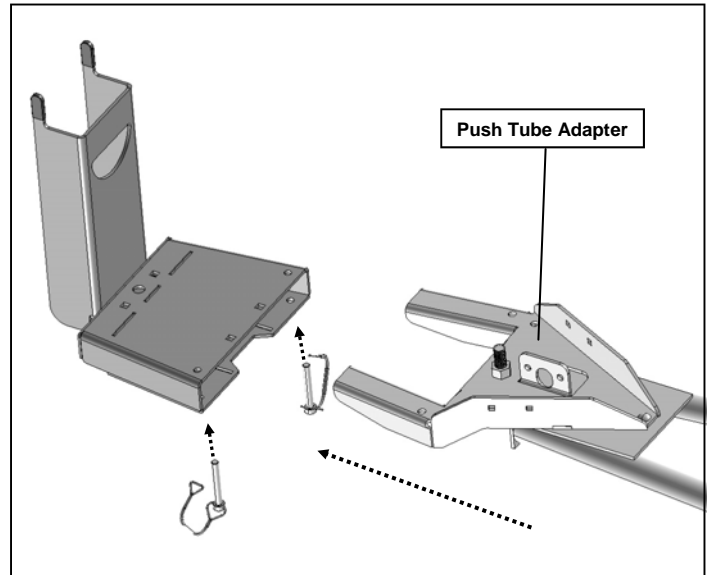

ILL. 3



## **One Year Limited Warranty**

For the period of one (1) year from the purchase date, Cycle Country Accessories Corporation will replace for the original purchaser, free of charge, any part or parts found upon examination by Cycle Country Accessories Corporation to be defective in material, workmanship, or both.

All transportation costs incurred submitting product to Cycle Country for warranty consideration must be borne by the purchaser. If Cycle Country determines that the product must be returned to the factory for credit, please call 1-800-841-2222 for a Return Merchandise Authorization (RMA) number and shipping instructions.

This warranty does not apply to parts that have been damaged by accident, alteration, abuse, improper maintenance, normal wear, or other causes beyond the manufacturer's control. In order to protect you and your ATV, certain parts of the plow system and/or hardware are designed to fail when the equipment is over-stressed.

Peripheral products such as engines, electric motors, and actuators may carry an original manufacturer's warranty. Please call Cycle Country Accessories Corporation for more information.

**CYCLE COUNTRY ACCESSORIES CORPORATION**

**1701 38TH AVE W**

**SPENCER, IA 51301**

**SERVICE: 800-841-2222 FAX: 712-262-0248**

**E-MAIL: [ccac@cyclecountry.com](mailto:ccac@cyclecountry.com)**

**WEB: [www.cyclecountry.com](http://www.cyclecountry.com)**